

# ODU MINI-SNAP

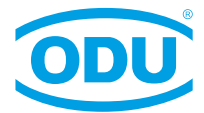

*A perfect alliance.*

## Miniature Circular Connectors with Push-Pull Locking Series L, K, B



## Miniature Circular Connectors with Push-Pull Locking, Series L, K, B



### Applications

- Medical devices
- Test and laboratory
- Measurement instrumentation
- Data and telecom systems
- Audio and video applications
- Military and security
- Industrial controls
- Nuclear technology.

### Features

- Quick and easy mating and demating
- Blind mating in difficult-to-reach places
- Less panel space required
- Definite and secure locking condition
- Robotic mating and demating possible
- Easy cleaning of housing possible
- High connector density
- Low space requirements.

**All shown connectors are according to DIN EN 61984:2009 connectors without breaking capacity (COC).**

All dimensions in mm. Most of the pictures are illustrations. All data and specifications subject to change without notice.

ODU MINI-SNAP is UL-listed under File E110586 00RT03566. MIL-Specification: Tests carried out (see page [113](#)).

Issue 2014-05

## Table of Contents (Part I)

Chapter		From page	
1	<b>Product description ODU MINI-SNAP series L, K, B</b>	<b><u>5</u></b>	
	The ODU MINI-SNAP family of miniature circular connectors	<u>6</u>	
	Important issues at a glance	<u>7</u>	
	Turned contact	<u>7</u>	
2	<b>ODU MINI-SNAP series L</b>	<b><u>9</u></b>	
	Push-Pull locking principle LP	<u>10</u>	
	LP locking scheme in cross section	<u>11</u>	
	Available housing sizes	<u>11</u>	
	Housings	<u>12</u>	
	Details for the part number key series L (keyings, housing materials/surfaces, collet system and bend protection sleeves)	<u>23</u>	
3	<b>ODU MINI-SNAP series K</b>	<b><u>29</u></b>	
	Push-Pull locking principle LP	<u>30</u>	
	LP locking scheme in cross section	<u>31</u>	
	Available housing sizes	<u>31</u>	
	Housings	<u>32</u>	
	Details for the part number key series K (keyings, housing materials/surfaces, collet system and bend protection sleeves)	<u>41</u>	
4	<b>ODU MINI-SNAP series B</b>	<b><u>47</u></b>	
	Push-Pull locking principle FP	<u>48</u>	
	FP locking scheme in cross section	<u>49</u>	
	Available housing sizes	<u>49</u>	
	Housings	<u>50</u>	
	Details for the part number key series B (keyings, housing materials/surfaces, collet system and bend protection sleeves)	<u>55</u>	
5	<b>Inserts series L, K, B</b>	<b><u>61</u></b>	
	Insulation body material	<u>62</u>	
	Size 00	<u>63</u>	
	Size 0	<u>64</u>	
	Size 1	<u>66</u>	
	Size 2	<u>68</u>	
	Size 3	<u>70</u>	
	Size 4	<u>72</u>	
	Contact type/surface	<u>73</u>	
	Contact diameter/termination cross section	<u>74</u>	
	PCB layout	<u>75</u>	

## Table of Contents (Part II)

Chapter		From page	
<b>6</b>	<b>Accessories</b>	<b><u>85</u></b>	
	Colour coding, ring, covers, bend relief, etc.		
<b>7</b>	<b>Tools</b>	<b><u>95</u></b>	
	Crimping tool	<u>96</u>	
	Crimping and removal tools for crimp contacts	<u>97</u>	
	Spanner wrench	<u>98</u>	
	Nutdriver for slotted mounting nut	<u>98</u>	
	Removal tool for crimp-clip-contacts	<u>99</u>	
	Assembly tool series K	<u>99</u>	
<b>8</b>	<b>Assembly instructions</b>	<b><u>101</u></b>	
	Available crimping instructions	<u>102</u>	
<b>9</b>	<b>Technical information</b>	<b><u>103</u></b>	
	International protection (IP) classes (DIN EN 60 529)	<u>104</u>	
	Watertightness	<u>105</u>	
	Housing materials and surface finish	<u>106</u>	
	Insulation body material	<u>106</u>	
	Termination styles	<u>107</u>	
	Conversions AWG – cross section	<u>108</u>	
	Current load – contacts	<u>109</u>	
	Operating voltage acc. to SAE AS 13441-method 3001.1	<u>110</u>	
	Electromagnetic compatibility (EMC)	<u>111</u>	
	Autoclaving of ODU MINI-SNAP connectors	<u>112</u>	
	Test standard	<u>113</u>	
	Technical information/definitions/terms	<u>114</u>	
<b>10</b>	<b>Company information</b>	<b><u>117</u></b>	
	Quality management	<u>118</u>	
	Your partner in many application areas	<u>119</u>	
	Overview – all Push-Pull connectors series from ODU	<u>120</u>	
	The complete ODU product range	<u>121</u>	
	Everything from one source	<u>122</u>	
	Application specific connectors	<u>123</u>	
<b>11</b>	<b>Telefax inquiry</b>	<b><u>125</u></b>	
	<b>The part number key</b>	<b><u>126</u></b>	

## Product Description

### ODU MINI-SNAP Series L, K, B



## The ODU MINI-SNAP Family of Miniature Circular Connectors Features Push-Pull Locking

Circular connectors are generally available with several locking mechanisms.

### The most frequently used are

- Threaded-locking sleeve
- Bayonet-locking
- Push-Pull locking.

### Push-Pull connectors have a very simple locking mechanism

- As the plug is pushed into the receptacle, locking fingers on the plug snap into the receptacle creating a reliable connection between plug and receptacle.
- Pulling on the cable or the rear of plug causes the locking fingers to grab harder and a separation of plug and receptacle is almost impossible. Pulling on the outer plug housing causes the locking fingers to retract and the plug and receptacle separate easily.



ODU MINI-SNAP series L (see page [9](#))



ODU MINI-SNAP series K (see page [29](#))



ODU MINI-SNAP series B (see page [47](#))

## Important Issues at a Glance

### Certification

The series is certified acc. **RoHS** 2011/65/EC and VDE.

### 8 sizes

Connector with metal shells available in 8 sizes. Outside diameter between 6.5 mm and 42 mm. Number of contact positions: 1 to 40 positions, mixed insert arrangements.

### Extensive range of termination possibilities

Plugs and in-line receptacles are offered with solder and crimp termination. Receptacles are available for solder, crimp, and PCB termination.

### Applications

	Insulation body material	Contact material
	PEEK	Ms
General application requirements (-40°C to +120°C)	●	●
Connectors which are autoclavable (+134°C, see page 112)	●	●

### Termination style

	Insulation body material	Contact material
	PEEK	Ms
Crimp termination	●	
Solder termination	●	
Printed circuit board (PCB) termination	●	

### Environmental protection classification

IP 50 up to IP 68 are available

## Turned Contact

Turned contacts are available in the diameters 0.5 to 4.0 mm. The contacts are available with following terminations: **Solder, crimp and print.**

Mating cycles	> 5,000
Material	Brass
Treatment processing	At least 1.25 µm Ni; at least 0.75 µm Au on the mating area

**For information regarding diameter, termination style and current load please see the contact configuration section.**

### Termination standard pin contacts

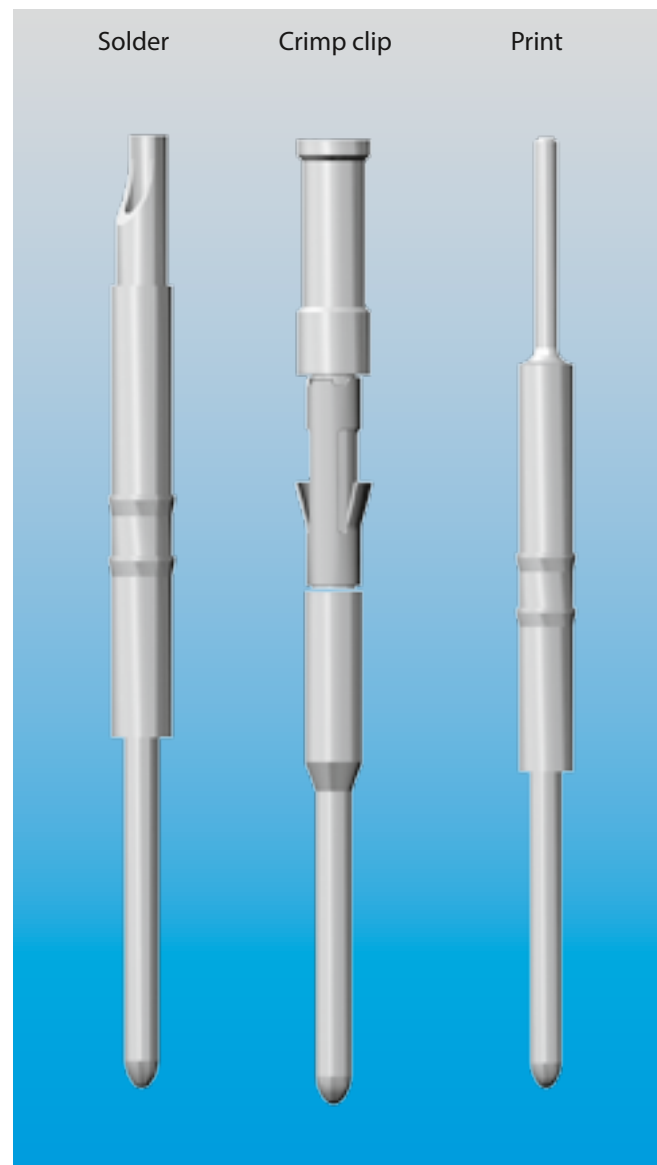





## Series L, IP 50 (and IP 68)

LP Locking Principle  
Keying with Pin and Groove



Series L



### Push-Pull Locking Principle LP

Connector in **unmated** condition.

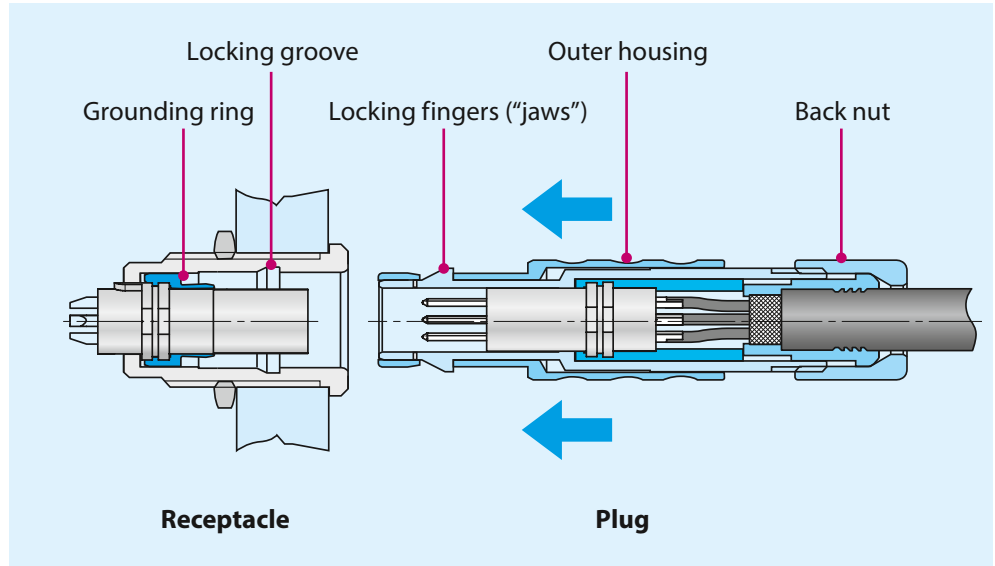

Connector in **mated** condition.

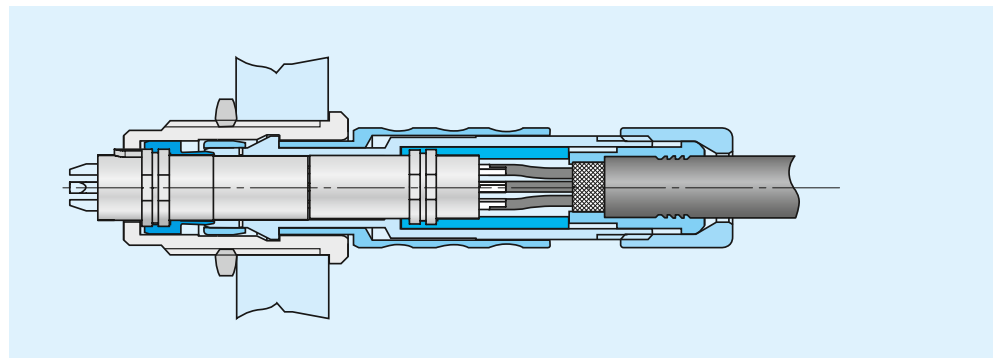

Pulling on the cable or on the back nut causes the "jaws" to grip harder into the groove in the receptacle. A separation is virtually impossible.

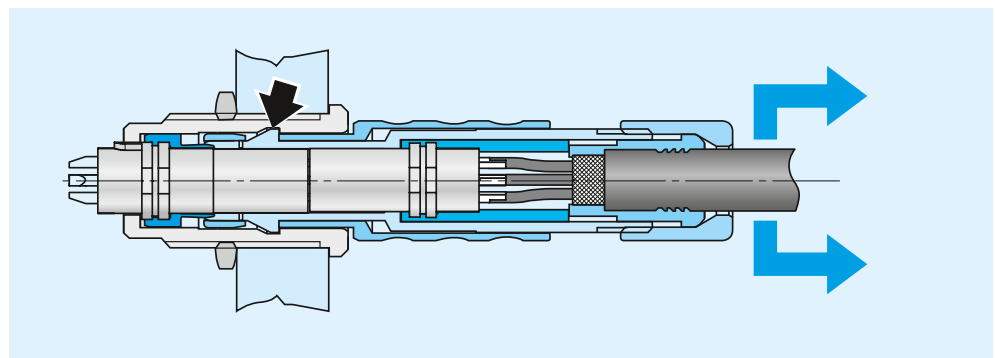

Pulling on the outer plug housing disengages the "jaws" from the receptacle groove and the connector separates easily.

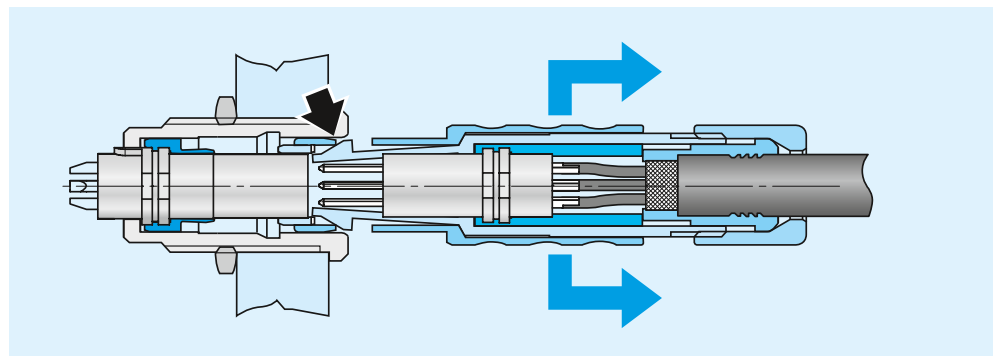

**ODU MINI-SNAP L**  
with LP Locking Scheme in Cross Section

Series L

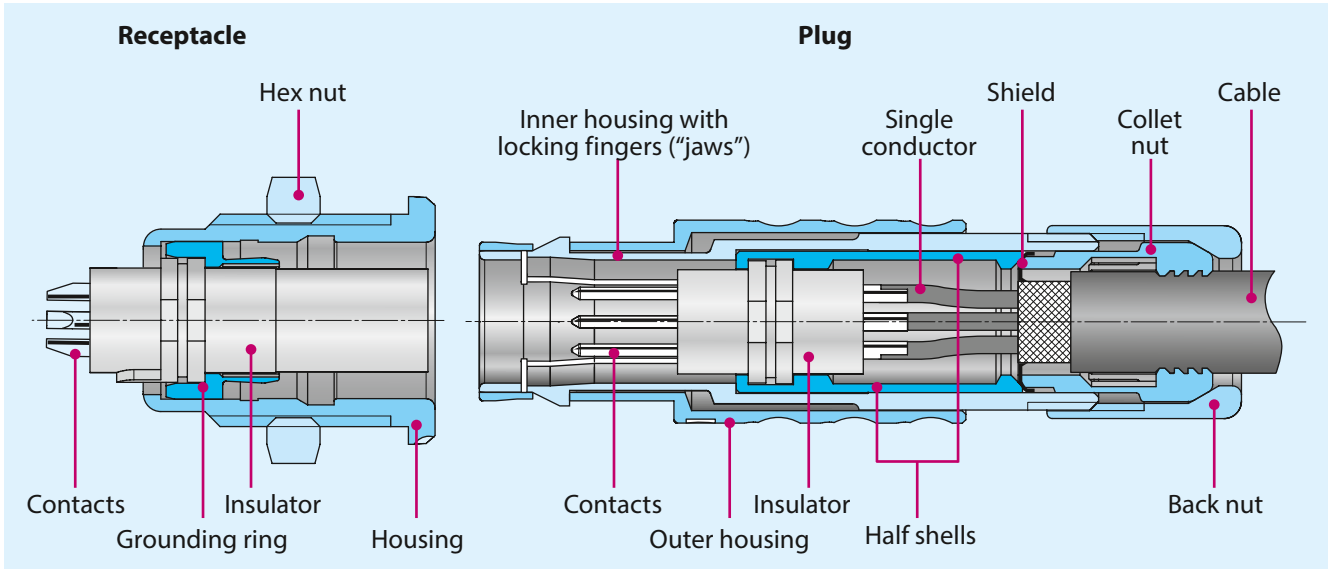

**Available Housing Sizes**

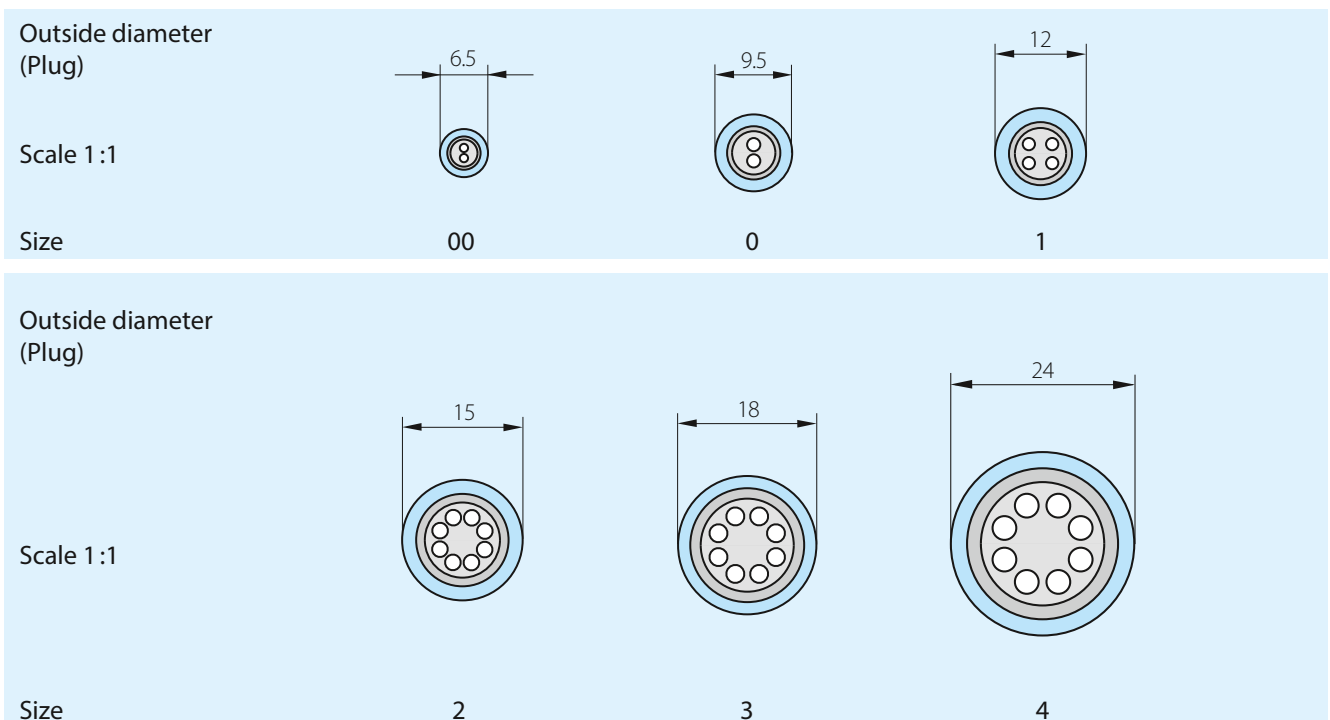

## Straight Plug

Series L

### Connector type

1	2	3	4	5	6	7	8	9	10	11	12	13	14	15	16	17	18	19
			L			-								-				0

S 1

Style 1: IP 50, with standard back nut

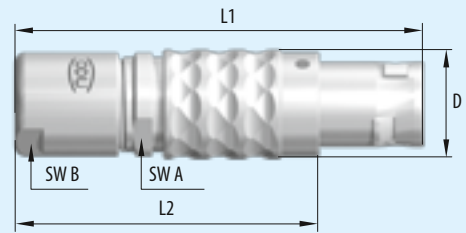

S 2

Style 2: IP 50, with back nut for cable bend relief<sup>1)</sup>

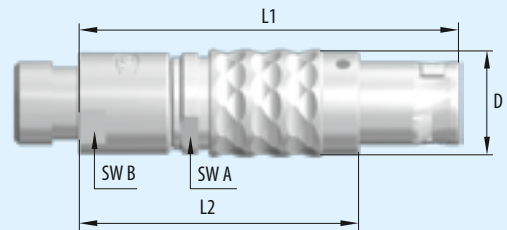

C	Size	Dimensions in mm					S1	S2
		L1	L2	D	SW A	SW B	SW B	
	00	~ 28.0	~ 20.0	6.4	5.5	5	5	
	0	~ 36.0	~ 26.0	9.0	8	7	7	
	1	~ 43.0	~ 32.0	11.5	10	10	10	
	2	~ 50.0	~ 38.0	14.5	13	12	13	
	3	~ 61.0	~ 46.0	17.5	15	14	15	
	4	~ 76.0	~ 58.0	25.0	21	20	20	

#### Technical data

– Contact configuration see page 61.

<sup>1</sup> Cable bend reliefs have to be ordered separately (see page 92).

<sup>2</sup> only S1

### Break-Away Plug (with Latching)

**Connector type**

1	2	3	4	5	6	7	8	9	10	11	12	13	14	15	16	17	18	19
			L			-								-				0

A 1

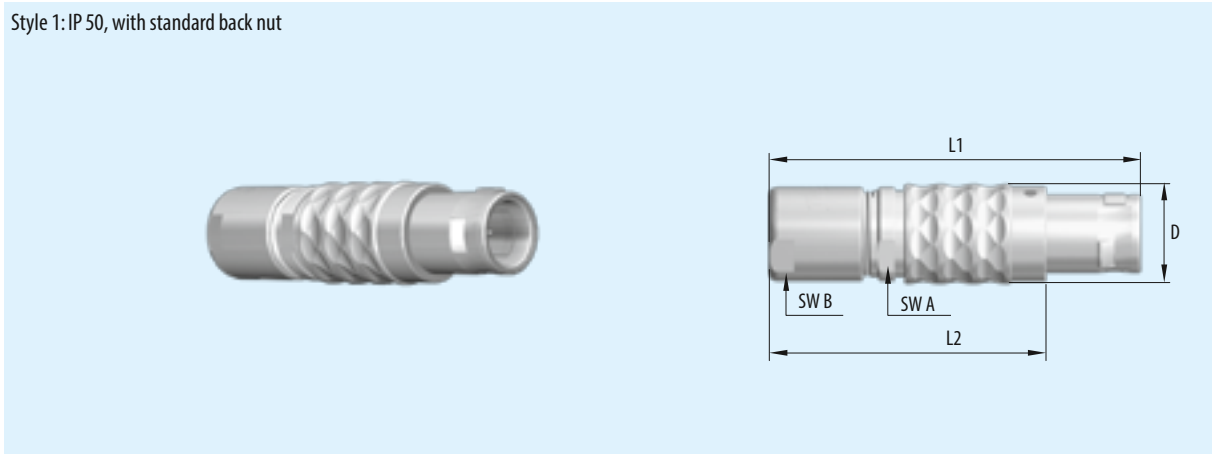

A 2

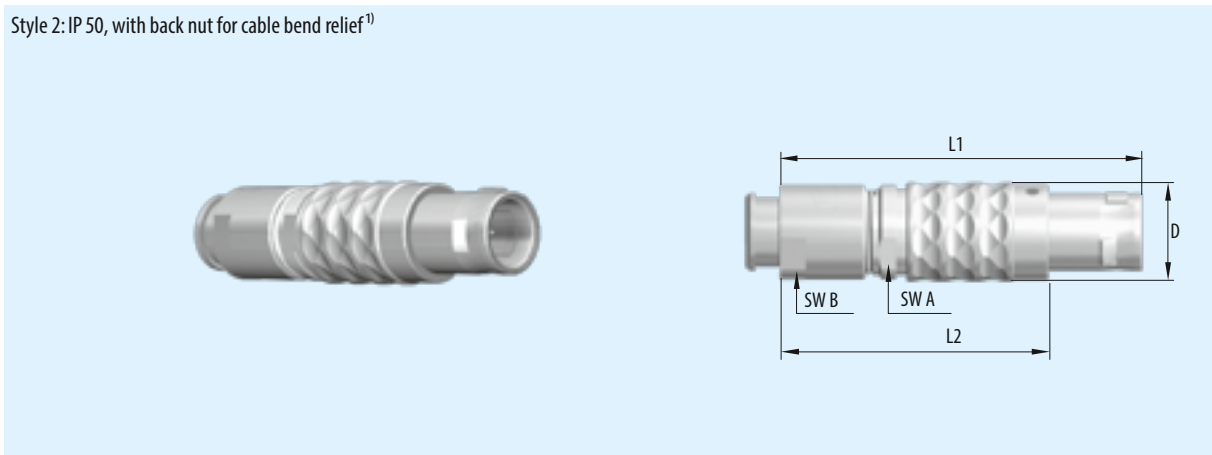

C	Size	Dimensions in mm				A1	A2
		L1	L2	D	SW A	SW B	SW B
	00	~ 28.0	~ 20.0	6.4	5.5	5	5
	0	~ 36.0	~ 26.0	9.0	8	7	7
	1	~ 43.0	~ 32.0	11.5	10	10	10
	2	~ 50.0	~ 38.0	14.5	13	12	13
	3	~ 61.0	~ 46.0	17.5	15	14	15

**Technical data**

- Contact configuration see page 61
- Connector can be separated by pulling the cable.

<sup>1)</sup> Cable bend reliefs have to be ordered separately (see page 92).

## Panel-Mounted Plug

Created to Build Up a Docking Connection Between 2 Instruments (E.g. a Charging Station)

Series L

### Connector type

1	2	3	4	5	6	7	8	9	10	11	12	13	14	15	16	17	18	19	
			L			-									-			0	0

A A

Style A: IP 50, with hex nut, non-latching, installation from front of panel

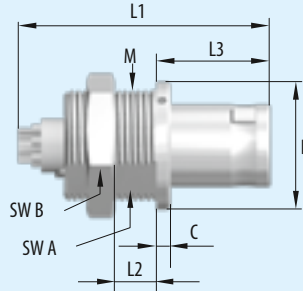
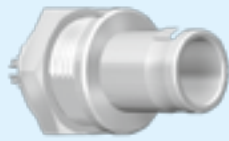

### Blueprint panel cut-out

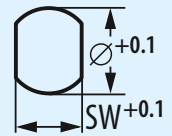

Size	Dimensions in mm								Panel cut-out		
	L1 <sup>1)</sup>	L2	L3	C	D	SW A	SW B	M	SW	∅	
C	00	~ 17.5	~ 4.5	9.0	1.0	8.0	6.3	9	7×0.5	6.4	7.1
0	0	~ 21.0	~ 3.5	11.2	1.2	10.0	8.2	11	9×0.5	8.3	9.1
1	1	~ 26.2	~ 7.0	12.3	1.5	14.0	10.5	14	12×1	10.6	12.1
2	2	~ 27.5	~ 7.0	13.8	1.8	18.0	13.5	17	15×1	13.6	15.1
3	3	~ 34.5	~ 9.0	17.0	2.0	22.0	16.5	22	18×1	16.6	18.1
4	4	~ 37.1	~ 8.0	20.5	2.5	28.0	23.5	30	25×1	23.6	25.1

### Technical data

- IP 50 in mated condition
- Anti-rotation feature
- Contact configuration and PCB layout see page 61.

<sup>1</sup> L1 = max. length incl. contact insert

A D

Style D: IP 50, with hex nut, non-latching, installation from front of panel

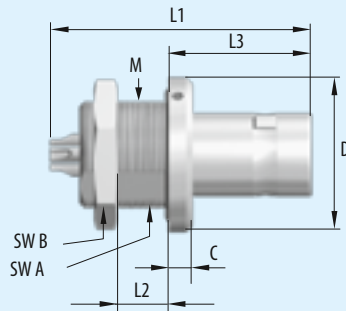
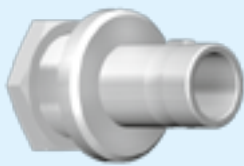

### Blueprint panel cut-out

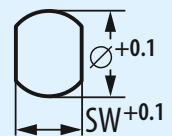

Size	Dimensions in mm								Panel cut-out		
	L1 <sup>1)</sup>	L2	L3	C	D	SW A	SW B	M	SW	∅	
0	0	~ 23.5	~ 5.5	12.0	2.0	13.0	8.2	11	9×0.5	8.3	9.1
1	1	~ 29.5	~ 8.0	13.3	2.5	17.0	10.5	14	12×1	10.6	12.1
2	2	~ 30.5	~ 7.0	14.8	2.8	19.5	13.5	17	15×1	13.6	15.1
3	3	~ 35.0	~ 7.5	18.0	3.0	24.0	16.5	22	18×1	16.6	18.1

### Technical data

- IP 68 in mated and unmated condition
- Anti-rotation feature
- Contact configuration and PCB layout see page 61
- No crimp contacts possible.

<sup>1</sup> L1 = max. length incl. contact insert

## Right-Angled Plug

### Connector type

1	2	3	4	5	6	7	8	9	10	11	12	13	14	15	16	17	18	19
			L			-								-				0

↑ ↑ ↑  
W 1

Style 1: IP 50, with standard back nut

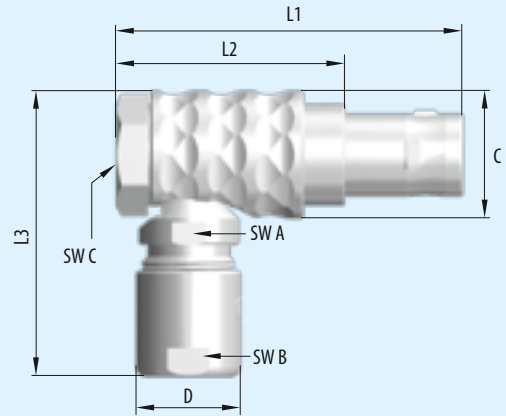
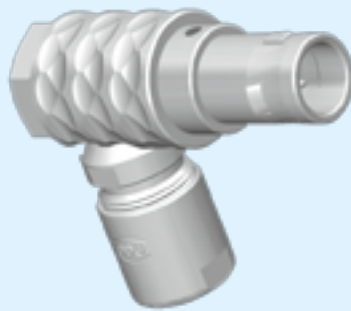

↑ ↑  
W 2

Style 2: IP 50, with back nut for cable bend relief<sup>1)</sup>

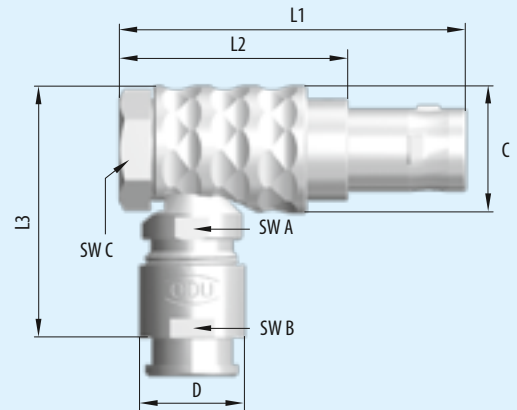
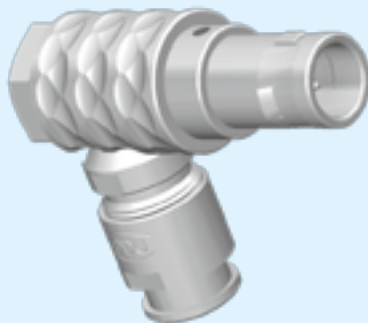

C	Dimensions in mm									
	Size	L1	L2	L3	C	D	SW A	W1 SW B	W2 SW B	SW C
00	~ 24.3	16.3	~ 18.5	7.8	6.4	5.5	5	5	7	
0	~ 30.0	20.0	~ 22.5	11.0	9.0	8	7	7	9	
1	~ 36.0	25.0	~ 29.0	13.5	11.0	10	10	10	11	
2	~ 41.5	29.5	~ 35.0	16.5	14.0	13	12	13	14	
3	~ 50.0	35.0	~ 36.5	19.0	16.5	15	14	15	17	
4	~ 65.0	47.0	~ 52.0	25.0	23.0	21	20	20	22	

### Technical data

– Contact configuration see page 61.

<sup>1)</sup> Cable bend reliefs have to be ordered separately (see page 92).

## In-Line Receptacle

Connect to Plug for Cable to Cable Connection

Series L

### Connector type

1	2	3	4	5	6	7	8	9	10	11	12	13	14	15	16	17	18	19
			L			-									-			0

**K 1**

Style 1: IP 50, with standard back nut

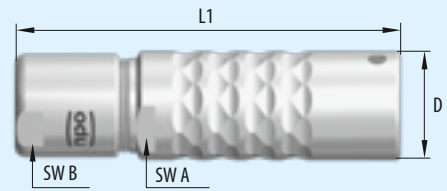

**K 2**

Style 2: IP 50, with back nut for cable bend relief<sup>1)</sup>

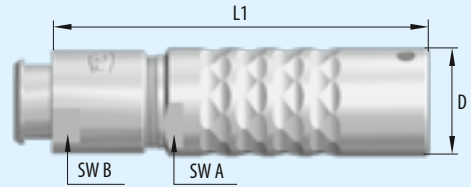

C	Size	Dimensions in mm				
		L1	D	SW A	K1 SW B	K2 SW B
	00	~ 27.0	6.4	5.5	5	5
	0	~ 35.0	9.4	8	7	7
	1	~ 41.0	11.5	10	10	10
	2	~ 47.0	14.5	13	12	13
	3	~ 57.0	17.5	16	14	15
	4	~ 74.0	23.5	21	20	20

### Technical Data

– Contact configuration see page 61.

<sup>1)</sup> Cable bend reliefs have to be ordered separately (see page 92).



Receptacle

Connector type

1	2	3	4	5	6	7	8	9	10	11	12	13	14	15	16	17	18	19	
			L			-								-				0	0

G 1

Style 1: IP 50, installation from front of panel

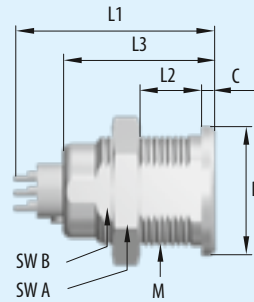
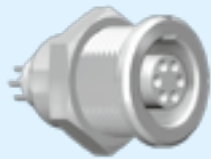

Blueprint panel cut-out

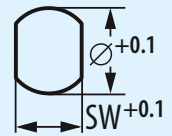

Size	Dimensions in mm								Panel cut-out	
	L1 <sup>1)</sup>	L2	L3 <sup>2)</sup>	M	D	SW A	SW B	C	SW	∅
C 00	~ 16.0	~ 7.0	12.0	7×0.5	8.0	9.0	6.3	1.0	6.4	7.1
0	~ 20.0	~ 9.0	14.5	9×0.5	10.0	11.0	8.2	1.5	8.3	9.1
1	~ 24.0	~ 8.0	16.5	12×1	14.0	14.0	10.5	1.5	10.6	12.1
2	~ 27.0	~ 10.0	18.5	15×1	18.0	17.0	13.5	1.8	13.6	15.1
3	~ 30.5	~ 13.0	22.5	18×1	22.0	22.0	16.5	2.0	16.6	18.1
4	~ 35.0	~ 13.0	27.0	25×1	28.0	30.0	23.5	2.5	23.6	25.1

Technical data

- IP 50
- Anti-rotation feature
- Contact configuration and PCB layout see page 61.

<sup>1</sup> L1 = max. length incl. contact insert  
<sup>2</sup> L3 = length of housing.

G 5

Style 5: IP 50, continuous thread, installation from rear or front of panel. Front extension adjustable.

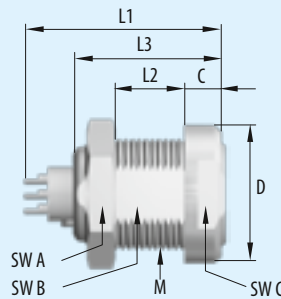
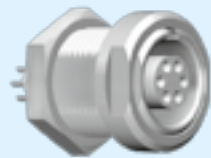

Blueprint panel cut-out

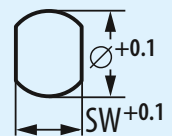

Size	Dimensions in mm								Panel cut-out		
	L1 <sup>1)</sup>	L2	L3 <sup>2)</sup>	M	D	SW A	SW B	SW C	C	SW	∅
C 00	~ 16.0	~ 6.0	12.0	7×0.5	9.0	9.0	6.3	8.0	2.0	6.4	7.1
0	~ 20.0	~ 8.0	14.5	9×0.5	11.5	11.0	8.2	10.0	2.5	8.3	9.1
1	~ 24.0	~ 8.0	16.5	12×1	15.0	14.0	10.5	13.0	4.0	10.6	12.1
2	~ 27.0	~ 10.0	18.5	15×1	20.0	17.0	13.5	17.0	3.8	13.6	15.1
3	~ 30.5	~ 12.0	22.5	18×1	23.0	22.0	16.5	20.0	5.0	16.6	18.1
4	~ 35.0	~ 10.5	27.0	25×1	30.0	30.0	23.5	27.0	4.5	23.6	25.1

Technical data

- IP 50
- Anti-rotation feature
- Contact configuration and PCB layout see page 61.

<sup>1</sup> L1 = max. length incl. contact insert  
<sup>2</sup> L3 = length of housing.

## Receptacle Style 6

Series L

### Connector type

1	2	3	4	5	6	7	8	9	10	11	12	13	14	15	16	17	18	19	
			L			-									-			0	0

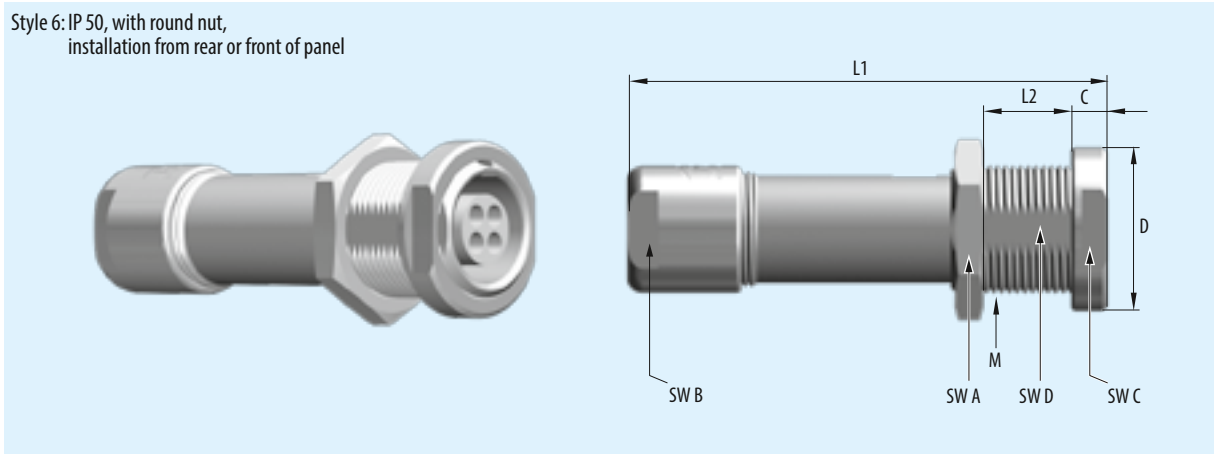

Size	Dimensions in mm										Panel cut-out	
	L1	L2	M	D	SW A	SW B	SW C	SW D	C	SW	∅	
0	0	~35.0	~6.0	9×0.5	11.5	11.0	7.0	10.0	8.2	2.5	8.3	9.1
1	1	~41.0	~5.0	12×1	15.0	14.0	10.0	13.0	10.5	4.0	10.6	12.1
2	2	~47.0	~6.5	15×1	20.0	17.0	12.0	17.0	13.5	3.8	13.6	15.1
3	3	~58.0	~9.0	18×1	23.0	22.0	14.0	20.0	16.5	5.0	16.6	18.1

#### Blueprint panel cut-out

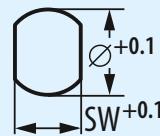

#### Technical data

- IP 50
- Anti-rotation feature
- Contact configuration see page 61.

Receptacle Style 8 and A

Connector type

1	2	3	4	5	6	7	8	9	10	11	12	13	14	15	16	17	18	19	
			L			-												0	0

G 8

Style 8: IP 68<sup>3)</sup> with slotted nut, installation from rear of panel

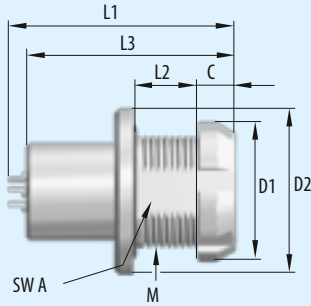
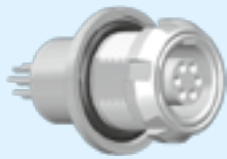

Blueprint panel cut-out

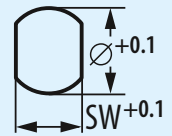

Size	Dimensions in mm									Panel cut-out	
	L1 <sup>1)</sup>	L2	L3 <sup>2)</sup>	M	D1	D2	SW A	C	SW	∅	
0	0	~22.5	~6.0	18.5	9×0.5	12.0	14.0	8.2	3.0	8.3	9.1
1	1	~27.0	~7.0	22.5	12×1	15.0	18.0	10.5	4.0	10.6	12.1
2	2	~29.5	~6.0	23.0	15×1	19.0	20.0	13.5	4.0	13.6	15.1
3	3	~32.0	~8.5	26.5	18×1	23.0	24.0	16.5	5.0	16.6	18.1

<sup>1</sup> L1 = max. length incl. contact insert  
<sup>2</sup> L3 = length of housing  
<sup>3</sup> Reference: potted receptacle see page 105.

**Technical data**  
 – IP 68 to the panel in mated or unmated condition  
 – Anti-rotation feature  
 – Contact configuration and PCB layout see page 61  
 – Nutdriver for slotted mounting nut see page 98  
 – No crimp contacts possible.

G A

Style A: IP 50, with round nut, installation from rear of panel

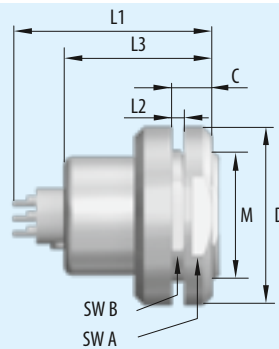
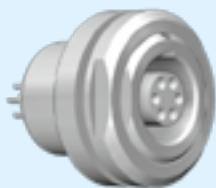

Blueprint panel cut-out

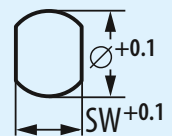

Size	Dimensions in mm									Panel cut-out	
	L1 <sup>1)</sup>	L2	L3 <sup>2)</sup>	M	D	SW A	SW B	C	SW	∅	
1	1	~24.0	~2.0	16.5	14×1	19.0	17.0	12.0	5.0	12.1	14.1
2	2	~27.0	~2.0	18.5	16×1	22.0	19.0	15.0	5.0	15.1	16.1
3	3	~30.5	~2.0	23.5	20×1	27.0	24.0	18.0	6.0	18.1	20.1

<sup>1</sup> L1 = max. length incl. contact insert  
<sup>2</sup> L3 = length of housing

**Technical data**  
 – IP 50  
 – Anti-rotation feature  
 – Contact configuration and PCB layout see page 61.

Receptacle Style F and G

Series L

Connector type

1	2	3	4	5	6	7	8	9	10	11	12	13	14	15	16	17	18	19	
			L			-									-			0	0

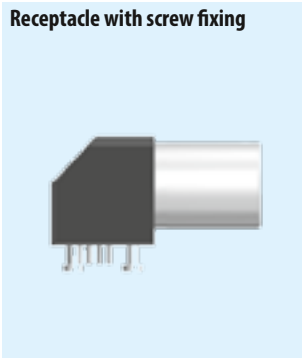
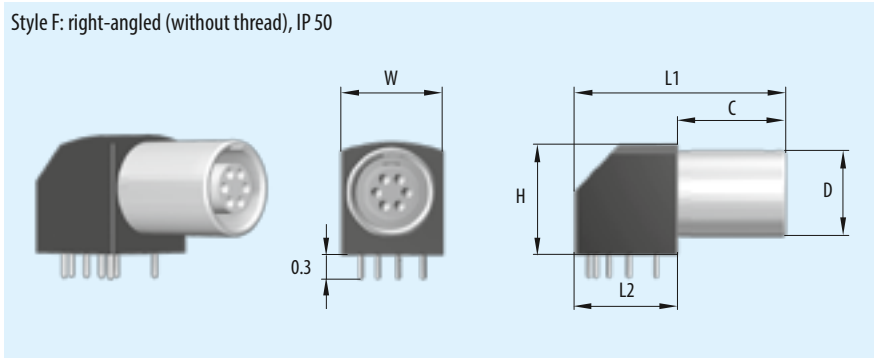

		Dimensions in mm						
Size		L1	L2	C	H	W	D	Max. positions
C	00	17.5	7.0	10.5	7.0	7.0	6.8	4
0	0	24.8	13.2	11.6	12.7	11.6	9.0	7
1	1	26.8	13.2	13.6	14.0	12.6	11.0	10

**Technical data**

- IP 50
- Contact configuration see page 61
- PCB layout see page 75
- Order information to the screw mounting see page 26.

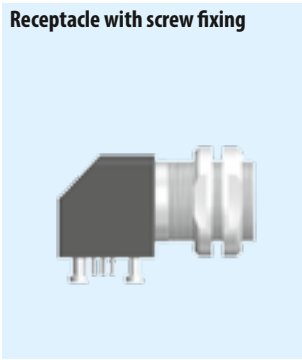
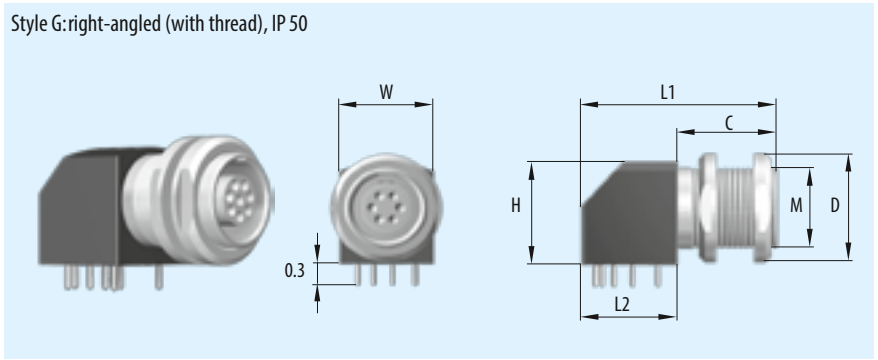

		Dimensions in mm							
Size		L1	L2	C	H	W	M	D	Max. positions
0	0	24.8	13.2	11.6	12.7	11.6	9×0.5	11.5	7
1	1	26.8	13.2	13.6	14.0	12.6	11×0.5	14.9	10

**Technical data**

- IP 50
- Contact configuration see page 61
- PCB layout see page 75
- Order information to the screw mounting see page 26.

Receptacle Style H and K

Connector type

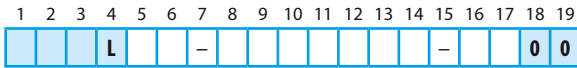

G H

Style H: IP 50, with low rear profile

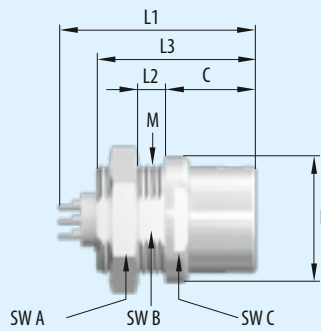
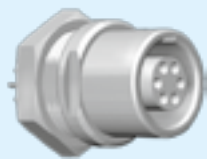

Blueprint panel cut-out

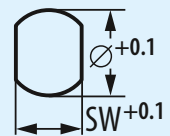

Size	Dimensions in mm										Panel cut-out	
	L1 <sup>1)</sup>	L2	L3 <sup>2)</sup>	M	D	SW A	SW B	SW C	C	SW	∅	
C	00	~16.0	~2.5	12.5	7×0.5	9.0	9.0	6.3	8.0	8.0	6.4	7.1
0	0	~20.0	~4.0	15.0	9×0.5	11.5	11.0	8.2	10.0	9.0	8.3	9.1
1	1	~24.0	~4.5	17.5	12×1	14.0	14.0	10.5	12.0	10.0	10.6	12.1
2	2	~27.0	~6.0	19.5	15×1	18.0	17.0	13.5	16.0	11.0	13.6	15.1
3	3	~30.5	~6.0	22.5	18×1	22.0	22.0	16.5	–	12.5	16.6	18.1

<sup>1)</sup> L1 = max. length incl. contact insert  
<sup>2)</sup> L3 = length of housing

Technical data

- IP 50
- Anti-rotation feature
- Contact configuration and PCB layout see page 61.

G K

Style K: IP 50, with round nut, installation from rear of panel

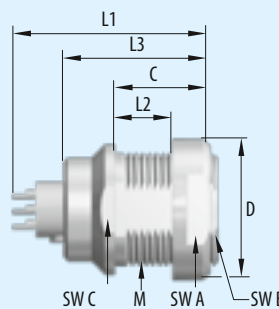

Blueprint panel cut-out

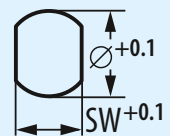

Size	Dimensions in mm										Panel cut-out	
	L1 <sup>1)</sup>	L2	L3 <sup>2)</sup>	M	D	SW A	SW B	SW C	C	SW	∅	
0	0	~20.0	~3.8	14.5	9×0.5	11.5	10.0	8.2	9.0	6.3	8.3	9.1
1	1	~24.0	~7.0	16.5	12×1	15.0	13.0	10.5	13.0	11.0	10.6	12.1
2	2	~27.0	~5.0	18.5	15×1	20.0	17.0	13.5	15.0	9.0	13.6	15.1
3	3	~30.5	~7.0	22.5	18×1	23.0	20.0	16.5	20.0	12.0	16.6	18.1
4	4	~35.0	~10.0	27.0	25×1	30.0	27.0	23.5	27.0	14.5	23.6	25.1

<sup>1)</sup> L1 = max. length incl. contact insert  
<sup>2)</sup> L3 = length of housing

Technical data

- IP 50
- Anti-rotation feature
- Contact configuration and PCB layout see page 61.

Receptacle Style L and P

Series L

Connector type

1	2	3	4	5	6	7	8	9	10	11	12	13	14	15	16	17	18	19	
			L			-									-			0	0

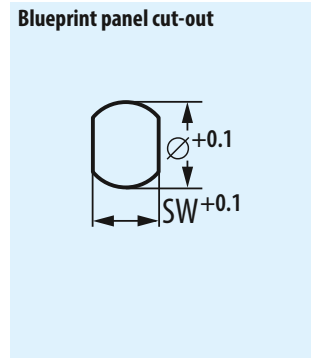
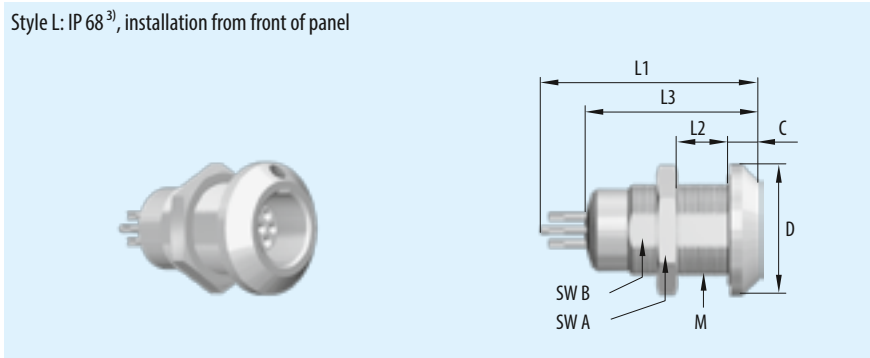

Size	Dimensions in mm								Panel cut-out	
	L1 <sup>1)</sup>	L2	L3 <sup>2)</sup>	M	D	SW A	SW B	C	SW	Ø
<b>C</b> 00	~18.0	~8.0	14.5	7×0.5	11.0	9.0	6.3	1.5	6.4	7.1
<b>0</b> 0	~22.5	~7.5	16.5	9×0.5	13.0	11.0	8.2	3.0	8.3	9.1
<b>1</b> 1	~27.0	~9.0	21.5	12×1	16.0	14.0	10.5	4.5	10.6	12.1
<b>2</b> 2	~29.5	~8.0	24.5	15×1	20.0	17.0	13.5	4.0	13.6	15.1

<sup>1</sup> L1 = max. length incl. contact insert  
<sup>2</sup> L3 = length of housing  
<sup>3</sup> Reference: Potted receptacle see page 105.

**Technical data**  
 – IP 68 to the panel in mated or unmated condition  
 – Anti-rotation feature  
 – Contact configuration and PCB layout see page 61  
 – No crimp contacts possible.

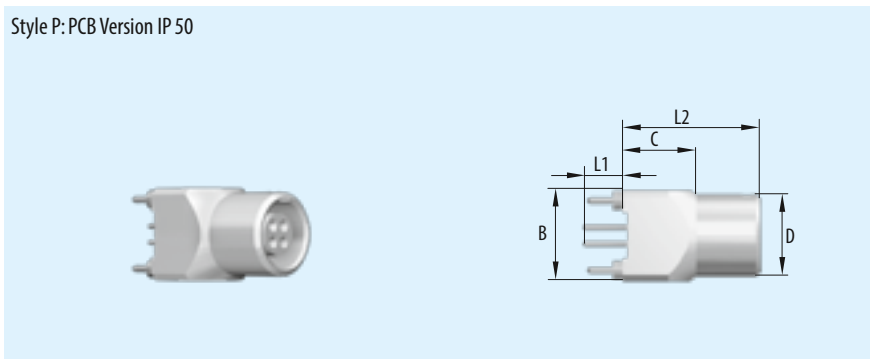

Size	Dimensions in mm				
	L1	L2	B	C	D
<b>0</b> 0	4.5	15.0	10.0	8.0	9.0
<b>1</b> 1	3.6	19.0	12.0	8.0	11.0

**Technical data**  
 – IP 50  
 – Contact configuration see page 61  
 – PCB layout on request.

## Details for the Part Number Key Series L

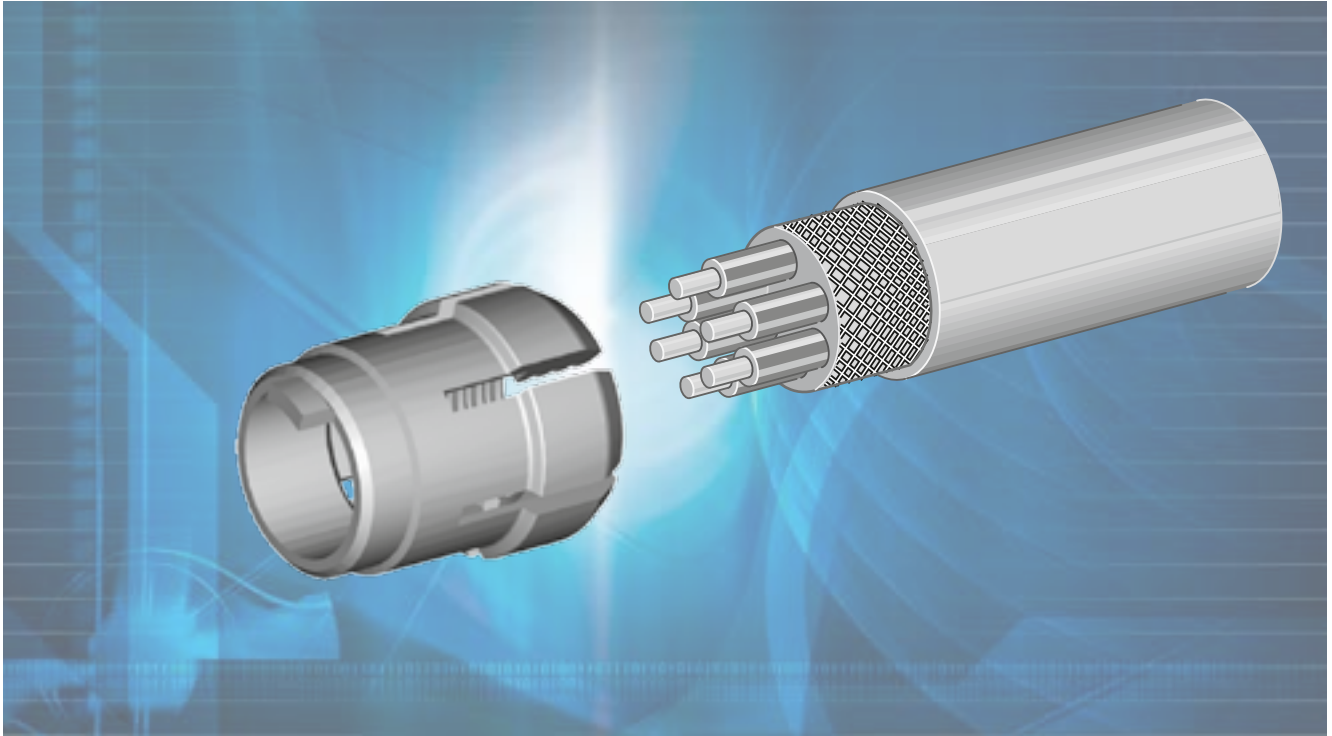

Series L



- Keyings**
- Housing Materials / Surfaces**
- Collet System**
- Bend Protection Sleeves**



Series L

### Keying Possibilities

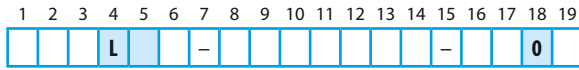

Angle	Keying	Receptacle front view	Size					
			00	0	1	2	3	4
0°	<b>0</b>		●	●	●	●	●	●
30°	<b>A</b>		●	●	●	●	●	○
37.5°	<b>B</b>					○	○	○
45°	<b>C</b>					●	●	○
-45°	<b>C</b>		●	●	●			
60°	<b>F</b>		●	●	●	●	●	○
90°	<b>J</b>			○	○			
95°	<b>K</b>					○	○	○
120°	<b>Q</b>					○	○	○
135°	<b>V</b>			○	○			
145°	<b>W</b>			○	○	○	○	○
155°	<b>Y</b>			○	○			

● Standard  
○ On request

### Housing Material

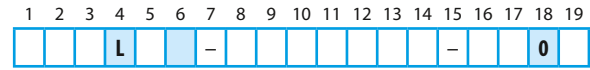

	Housing material	
Standard	<b>C</b>	Cu-alloy / matt chromate
On request	<b>S</b>	Cu-alloy / black chromate

Special materials and surfaces on request.



### Collet System

1	2	3	4	5	6	7	8	9	10	11	12	13	14	15	16	17	18	19
			L			-								-				0

Cable diameter in mm	Size						16	17	
	00	0	1	2	3	4			
> 0.5 – 1.0	●						1	0	
> 1.0 – 1.5	●						1	5	
> 1.5 – 2.0	●						2	0	
> 1.5 – 2.2		●	●				2	2	
> 2.0 – 2.5	●						2	5	
> 2.5 – 3.0	●						3	0	
> 2.0 – 3.2		●	●	●			3	2	
> 3.0 – 3.5	●*						3	5	
> 3.0 – 4.2		●	●	●	●		4	2	
> 4.0 – 5.2		●*	●	●	●		5	2	
> 5.0 – 5.6		●*					5	6	
> 5.0 – 6.2			●	●	●	●	6	2	
> 6.0 – 7.2			●*	●	●	●	7	2	
> 7.0 – 7.7			●*				7	7	
> 7.0 – 8.0						●	8	0	
> 7.0 – 8.2				●	●		8	2	
> 8.0 – 9.2				●*	●	●	9	2	
> 9.0 – 9.9				○*			9	9	
> 9.0 – 10.2					●		0	2	
> 9.1 – 10.5						●	0	2	
> 10.0 – 11.0						●	1	1	
> 10.0 – 11.2					●*		1	2	
> 11.0 – 11.9					○*	●	1	9	
> 12.0 – 13.0						●	1	3	
> 13.0 – 14.0						●	1	4	
> 14.0 – 15.0						●*	1	5	
> 15.0 – 16.0						●*	1	6	
without collet system (on request)								0	0

Useable for all plugs and in-line receptacles and receptacle style 6.  
Application: Collet nut for strain relief.

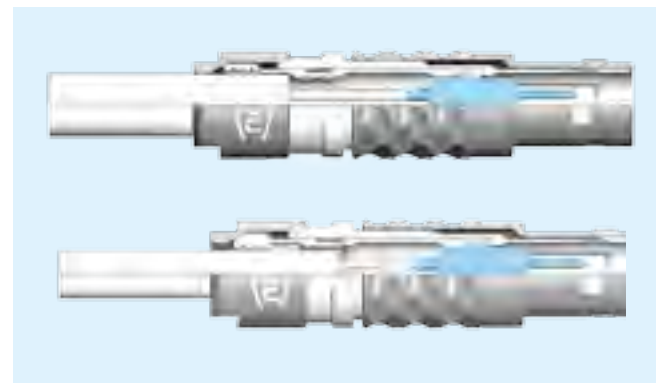
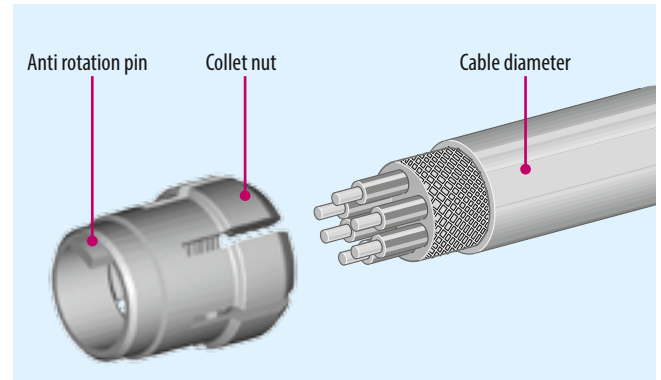

\* It's possible that the collet nut cannot be covered completely over the cable.

○ Reference: This diameters are not deliverable for applications with cable bend relief.

## Right-Angled Print Contacts in the Receptacle

Series L

1	2	3	4	5	6	7	8	9	10	11	12	13	14	15	16	17	18	19
			L			-				Q	0	0	-			0	0	

Right-angled print contact

A

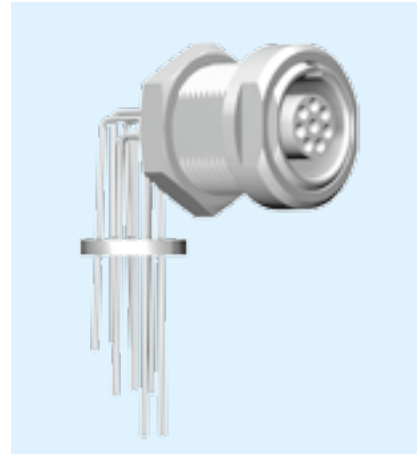

**Technical data**

- PCB layout see page 75
- Pin version on request

Receptacle style F and G with 4 solder pins (see page 20)

0

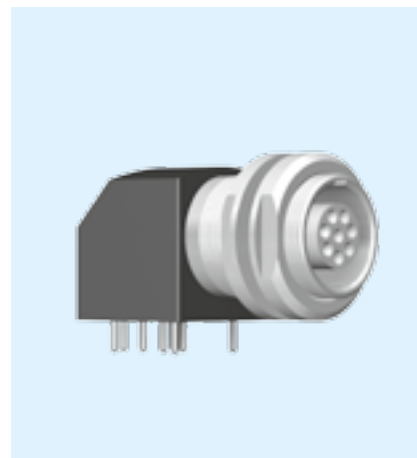

**Technical data**

- Pin version on request

Receptacle style F and G for screw mounting (see page 20)

S

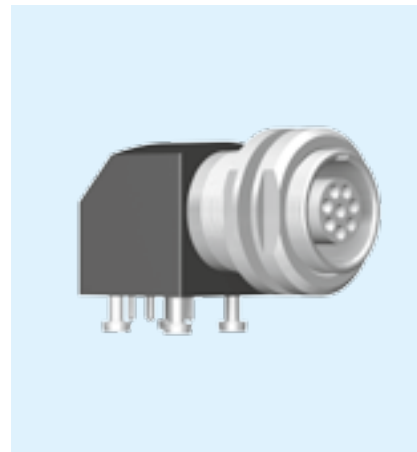

**Technical data**

- Max. tightening torque of the screws M1.4: 0.1 Nm

## Definition of the Back Nut

1	2	3	4	5	6	7	8	9	10	11	12	13	14	15	16	17	18	19
			L			-								-				0

Standard back nut

0

Back nut for silicone cable bend reliefs

S

Useable for all straight-angled Break-Away plugs, in-line receptacles, receptacles style 6.

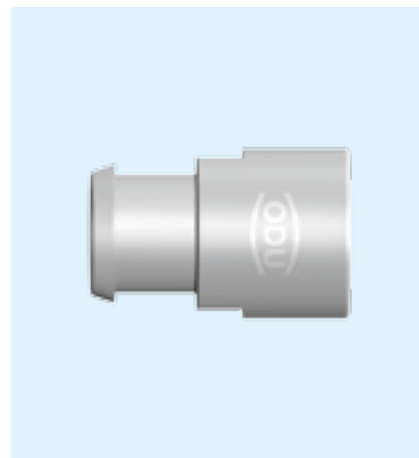

Cable bend reliefs see page [92](#).



**Series K, IP 68**  
**LP Locking Principle**  
**Keying with Pin and Groove**



Series K



**Push-Pull Locking Principle LP**

Series K

Connector in **unmated** condition.

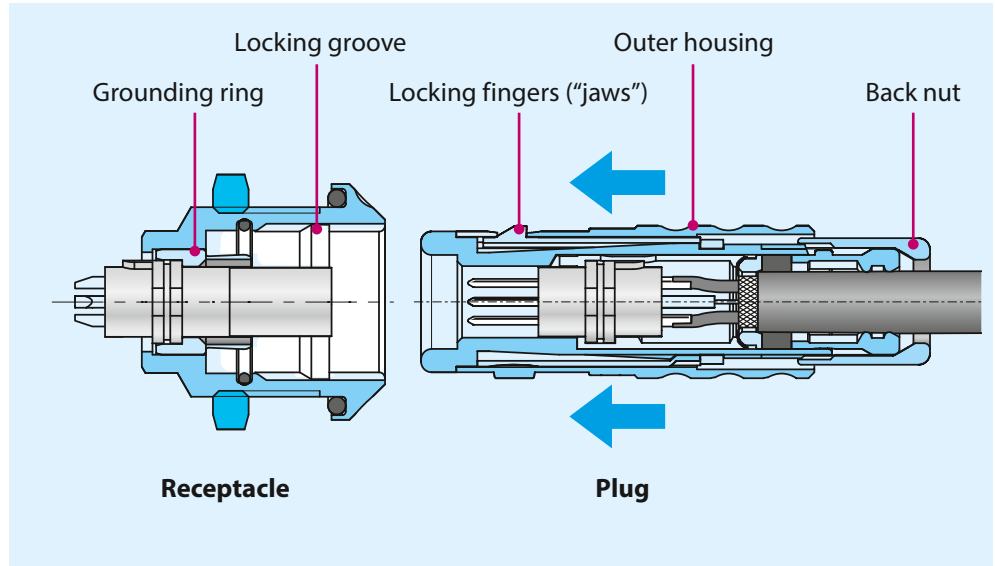

Connector in **mated** condition.

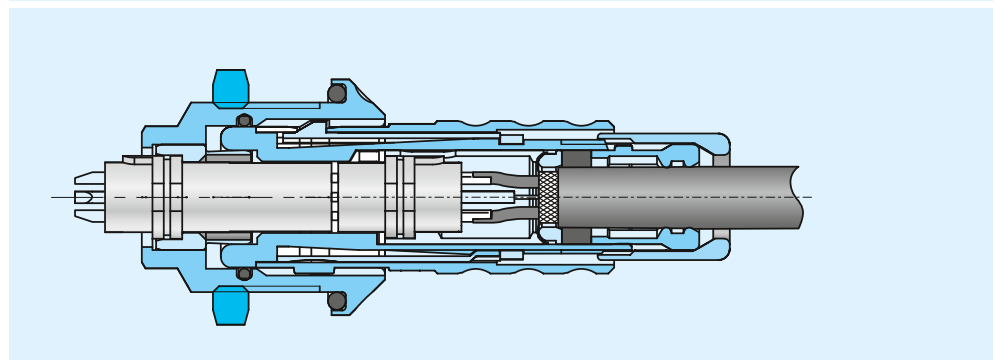

Pulling on the cable or on the back nut causes the "jaws" to grip harder into the groove in the receptacle. A separation is virtually impossible.

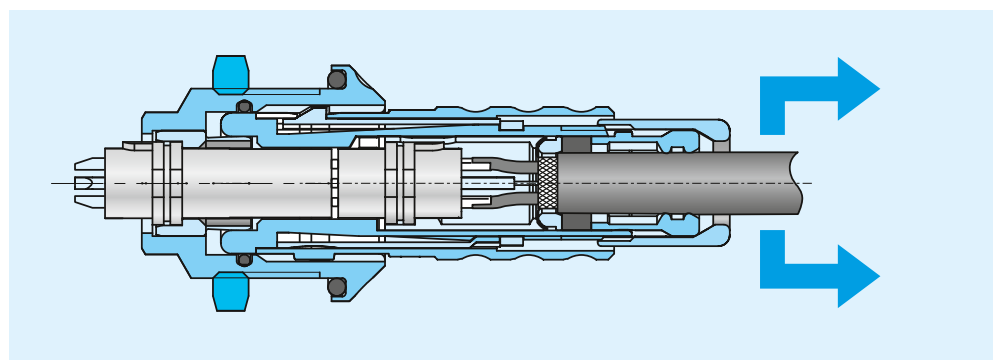

Pulling on the outer plug housing disengages the "jaws" from the receptacle groove and the connector separates easily.

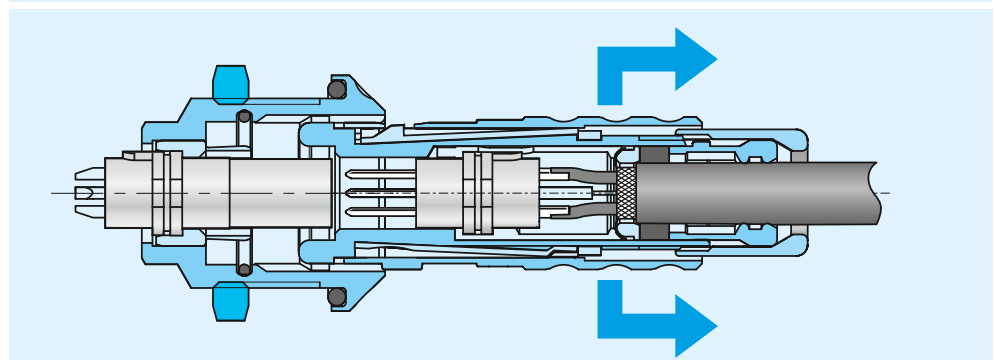

**ODU MINI-SNAP K**  
with LP Locking Scheme in Cross Section

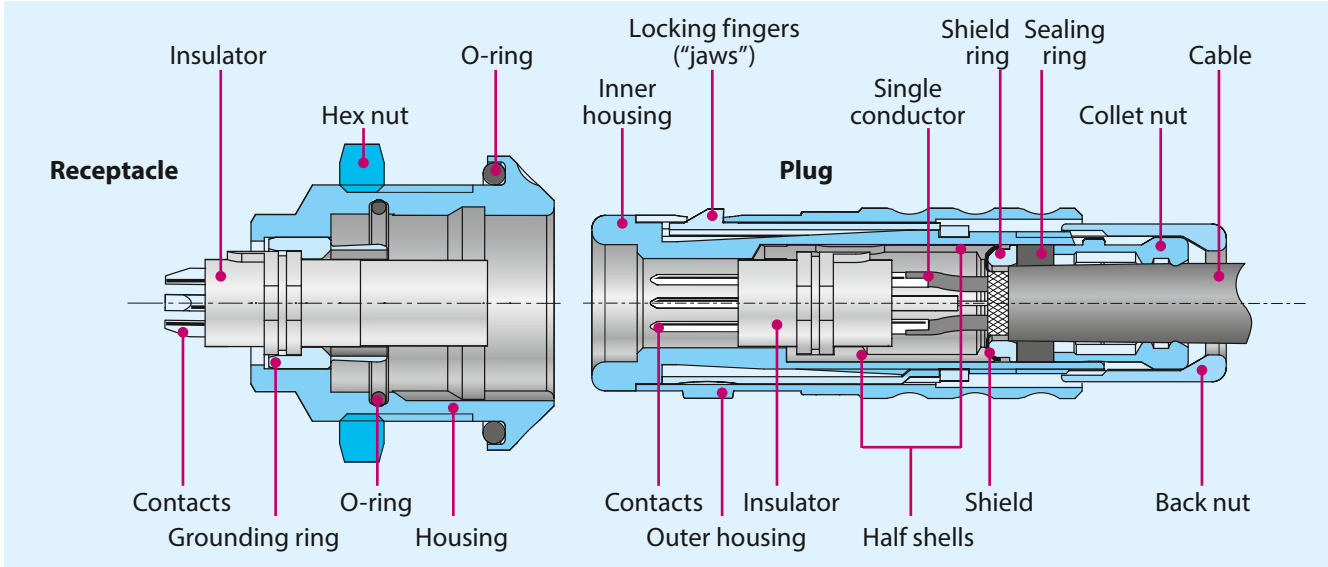

Series K

**Available Housing Sizes**

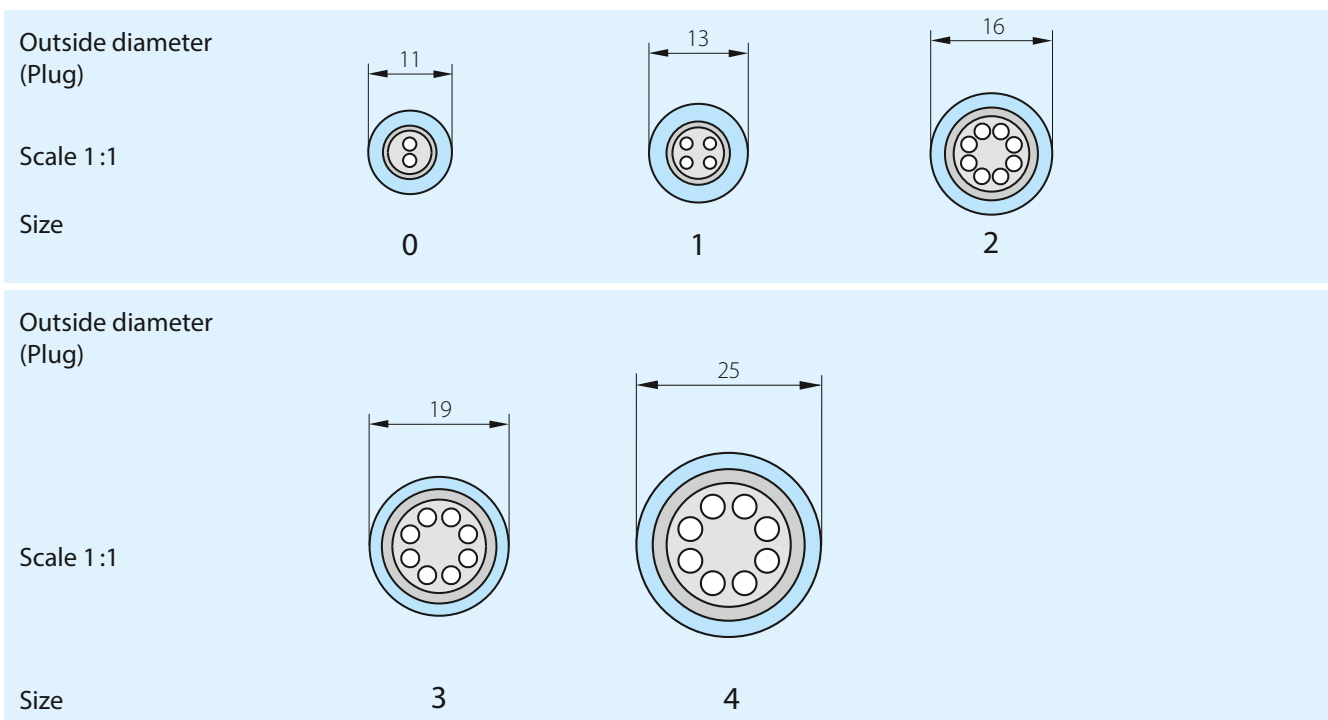

## Straight Plug

### Connector type

1	2	3	4	5	6	7	8	9	10	11	12	13	14	15	16	17	18	19
			K			-								-				0

Series K

S 1

Style 1: IP 68, with standard back nut

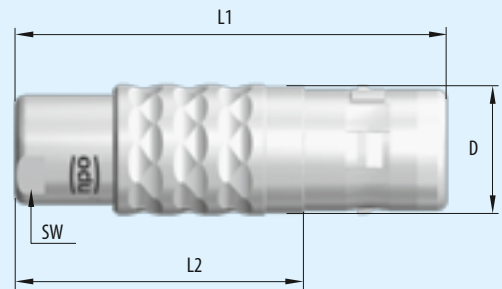

S 2

Style 2: IP 68, with back nut for cable bend relief<sup>1)</sup>

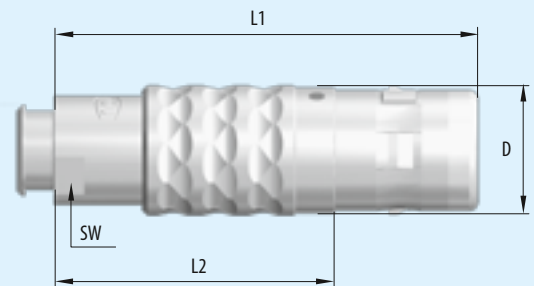

Size	Dimensions in mm					
	L1	L2	D	S1 SW B	S2 SW B	
0	~ 37.0	~26.0	11.0	7	7	
1	~ 44.0	~30.0	13.0	10	10	
2	~ 50.0	~34.0	16.0	12	13	
3	~ 60.0	~40.0	19.0	14	15	
4	~ 73.0	~52.0	25.0	20	20	

#### Technical data

– Contact configuration see page 61.

<sup>1)</sup> Cable bend reliefs have to be ordered separately (see page 92).



## Break-Away Plug

### Connector type

1	2	3	4	5	6	7	8	9	10	11	12	13	14	15	16	17	18	19
			K			-								-				0

A 1

Style 1: IP 68, with standard back nut

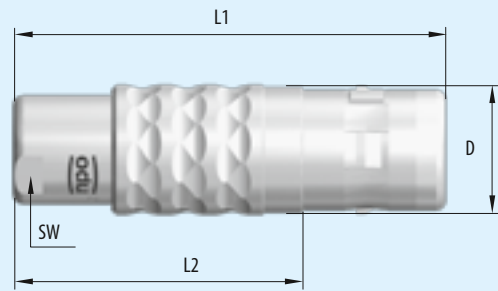

A 2

Style 2: IP 68, with back nut for cable bend relief<sup>1)</sup>

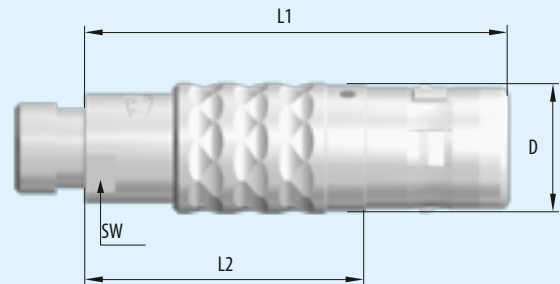

Size	Dimensions in mm				
	L1	L2	D	A1 SW	A2 SW
0	~ 37.0	~ 26.0	11.0	7	7
1	~ 44.0	~ 30.0	13.0	10	10
3	~ 60.0	~ 40.0	19.0	14	15

#### Technical data

- Contact configuration see page 61
- Connector can be separated by pulling the cable.

<sup>1)</sup> Cable bend reliefs have to be ordered separately (see page 92).

## Panel-Mounted Plug

Created to Build Up a Docking Connection Between 2 Instruments (E.g. a Charging Station)

### Connector type

1	2	3	4	5	6	7	8	9	10	11	12	13	14	15	16	17	18	19	
			K			-									-			0	0



Series K

Style A: IP 68, with hex nut, non-latching, installation from front of panel

Blueprint panel cut-out

Size	Dimensions in mm							Panel cut-out	
	L1 <sup>1)</sup>	L2	L3	M	D	SW A	SW B	SW	Ø
1	28.0	~ 4.0	16.3	16 × 1	20.0	14.5	18.5	14.6	16.1
2	32.0	~ 4.5	19.0	20 × 1	25.0	18.5	25.0	18.6	20.1

<sup>1</sup> L1 = max. length incl. contact insert

**Technical data**

- IP 68 in mated condition
- Anti-rotation feature
- Contact configuration and PCB layout see page 61.

Style D: IP 68, with hex nut, non-latching, installation from front of panel

Blueprint panel cut-out

Size	Dimensions in mm							Panel cut-out	
	L1 <sup>1)</sup>	L2	L3	M	D	SW A	SW B	SW	Ø
3	36.0	~ 4.0	23.2	24 × 1.0	31.0	22.5	30	22.6	24.1

<sup>1</sup> L1 = max. length incl. contact insert

**Technical data**

- IP 68 in mated and unmated condition
- Anti-rotation feature
- Crimp contacts not possible
- Contact configuration and PCB layout see page 61.

## Right-Angled Plug

### Connector type

1	2	3	4	5	6	7	8	9	10	11	12	13	14	15	16	17	18	19
			K			-								-				0

↑ ↑ ↑  
W 1

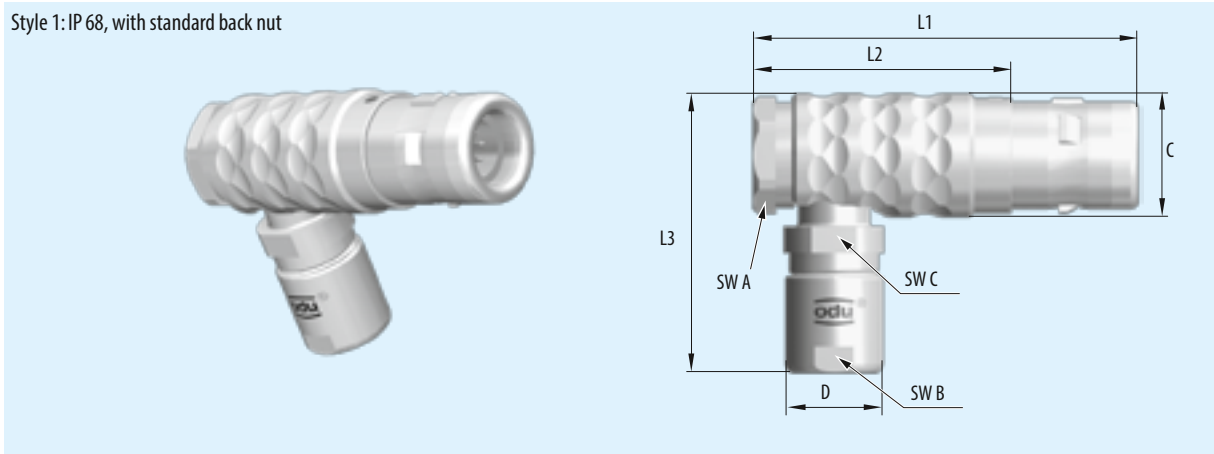

↑ ↑ ↑  
W 2

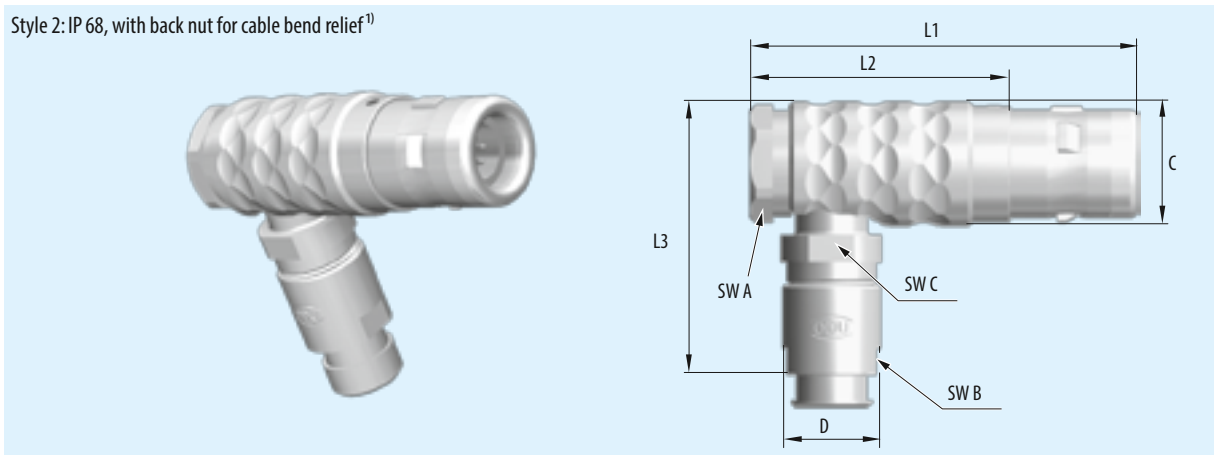

Size	Dimensions in mm									
	L1	L2	L3	C	D	SW A	W1 SW B	W2 SW B	SW C	
0	0	~34.7	23.2	~27.0	11.6	9.0	10	7	7	8
1	1	~43.0	28.7	~34.0	14.0	11.0	12	10	10	10
2	2	~51.0	34.7	~36.0	17.5	14.0	15	12	13	13
3	3	~61.0	40.8	~41.0	20.0	16.5	18	14	15	15

#### Technical data

– Contact configuration see page 61.

<sup>1)</sup> Cable bend reliefs have to be ordered separately (see page 92).

## In-Line Receptacle

Connect to Plug for Cable to Cable Connection

### Connector type

1	2	3	4	5	6	7	8	9	10	11	12	13	14	15	16	17	18	19
			K			-								-				0

Series K

K 1

Style 1: IP 68, with standard back nut

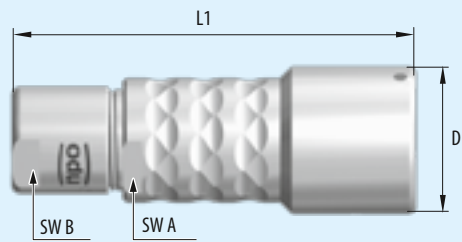
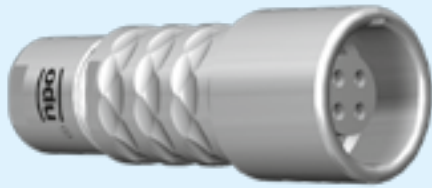

K 2

Style 2: IP 68, with back nut for cable bend relief<sup>1)</sup>

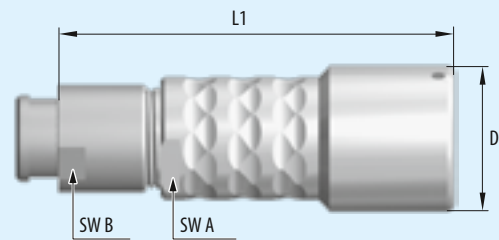

Size	Dimensions in mm				
	L1	D	SW A	K1 SW B	K2 SW B
0	~ 39.0	13.0	9.0	7	7
1	~ 47.0	15.0	11.0	10	10
2	~ 54.0	19.0	14.0	12	13
3	~ 64.0	23.0	16.5	14	15
4	~ 79.0	29.0	22.0	20	20

### Technical Data

– Contact configuration see page 61.

<sup>1)</sup> Cable bend reliefs have to be ordered separately (see page 92).

Receptacle

Connector type

1	2	3	4	5	6	7	8	9	10	11	12	13	14	15	16	17	18	19	
		K				-												0	0



Style 1: IP 68, installation from front of panel

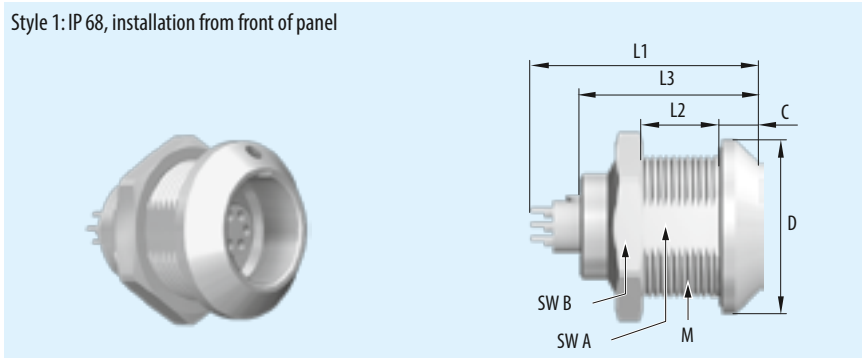

Blueprint panel cut-out

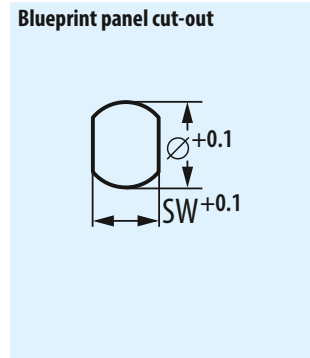

Size	Dimensions in mm								Panel cut-out	
	L1 <sup>1)</sup>	L2	L3 <sup>2)</sup>	M	D	SW A	SW B	C	SW	Ø
0	~21.0	~5.5	15.5	14×1	18.0	12.5	17.0	4.0	12.6	14.1
1	~28.0	~9.0	20.5	16×1	20.0	14.5	19.0	4.5	14.6	16.1
2	~31.0	~9.0	23.0	20×1	25.0	18.5	24.0	5.0	18.6	20.1
3	~36.0	~11.0	28.0	24×1	31.0	22.5	30.0	6.0	22.6	24.1
4	~40.0	~11.0	31.5	30×1	37.0	28.5	36.0	6.5	28.6	30.1

<sup>1</sup> L1 = max. length incl. contact insert  
<sup>2</sup> L3 = length of housing

Technical data

- IP 68 in mated condition
- Anti-rotation feature
- Contact configuration and PCB layout see page 61.

G 3

Style 3: IP 68 with slotted mounting nut, installation from rear of panel

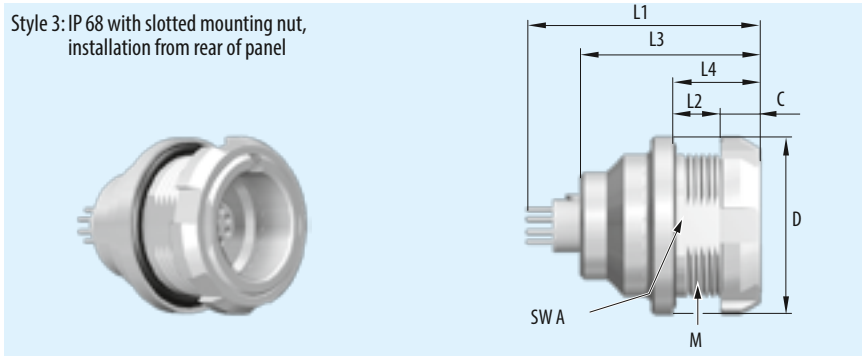

Blueprint panel cut-out

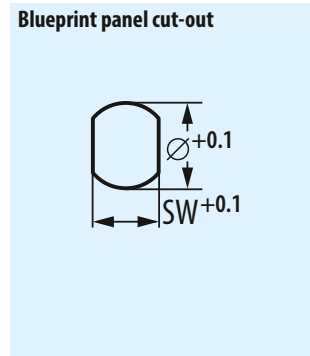

Size	Dimensions in mm								Panel cut-out		
	L1 <sup>1)</sup>	L2	L3 <sup>2)</sup>	L4	M	D	C	SW A	SW	Ø	
0	~21.0	~3.0	15.5	7.0	14×1	18.0	4.0	12.5	12.6	14.1	
1	~28.0	~6.0	20.5	10.0	16×1	20.0	3.5	14.5	14.6	16.1	
2	~31.0	~6.0	23.0	10.0	20×1	25.0	3.5	18.5	18.6	20.1	
3	3 <sup>3)</sup>	~36.0	~7.5	28.0	12.0	24×1	31.0	4.5	22.5	22.6	24.1
4	4	~40.0	~6.5	31.5	13.5	30×1	41.5	7.0	28.5	28.6	30.1

<sup>1</sup> L1 = max. length incl. contact insert  
<sup>2</sup> L3 = length of housing  
<sup>3</sup> Reference: size 3 with round nut SW 27.

Technical data

- IP 68 in mated condition
- Anti-rotation feature
- Contact configuration and PCB layout see page 61
- Nutdriver see page 98.

Receptacle

Connector type

1	2	3	4	5	6	7	8	9	10	11	12	13	14	15	16	17	18	19	
			K			-												0	0

G 4

Style 4: IP 68<sup>3)</sup>, installation from front of panel with low rear profile

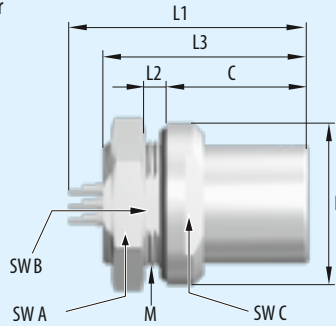
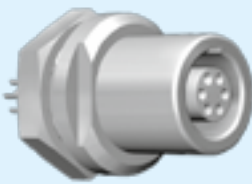

Blueprint panel cut-out

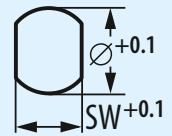

Size	Dimensions in mm									Panel cut-out	
	L1 <sup>1)</sup>	L2	L3 <sup>2)</sup>	M	D	SW A	SW B	SW C	C	SW	Ø
1	~ 28.0	~ 1.5	20.5	16 × 1	20.0	19	14.5	17.0	15.5	14.6	16.1
2	~ 31.0	~ 2.0	23.0	20 × 1	25.0	24	18.5	20.0	17.0	18.6	20.1

<sup>1</sup> L1 = max. length incl. contact insert  
<sup>2</sup> L3 = length of housing  
<sup>3</sup> Reference: Potted receptacle see page 105.

Technical data

- IP 68 in mated and unmated condition
- Anti-rotation feature
- Contact configuration and PCB layout see page 61
- No crimp contacts possible.

G 8

Style 8: IP 68, with slotted mounting nut, installation from rear of panel

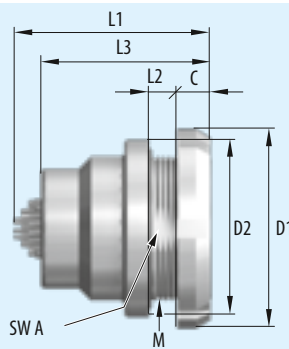
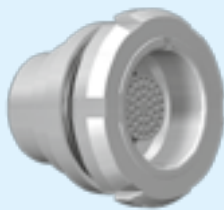

Blueprint panel cut-out

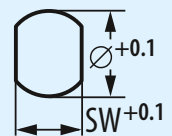

Size	Dimensions in mm									Panel cut-out	
	L1 <sup>1)</sup>	L2	L3 <sup>2)</sup>	M	D1	D2	SW A	C	SW	Ø	
1	~ 32.0	~ 6.0	26.6	16 × 1	20.0	20.0	14.5	3.5	14.6	16.1	
2	~ 34.0	~ 6.0	27.0	20 × 1	25.0	25.0	18.5	3.5	18.6	20.1	
3	~ 39.0	~ 7.0	32.7	24 × 1	30.0	31.0	22.5	4.5	22.6	24.1	
4	~ 42.0	~ 6.0	35.5	30 × 1	41.5	37.0	28.5	7.0	28.6	30.1	

<sup>1</sup> L1 = max. length incl. contact insert  
<sup>2</sup> L3 = length of housing  
<sup>3</sup> Reference: size 3 with round nut SW 27.

Technical data

- IP 68 in mated and unmated condition
- Anti-rotation feature
- Crimp contacts not possible
- Contact configuration see page 61.

Series K

**Connector type**

1	2	3	4	5	6	7	8	9	10	11	12	13	14	15	16	17	18	19	
			K			-									-			0	0

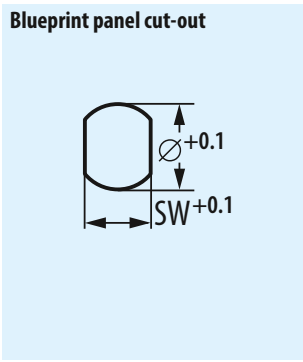
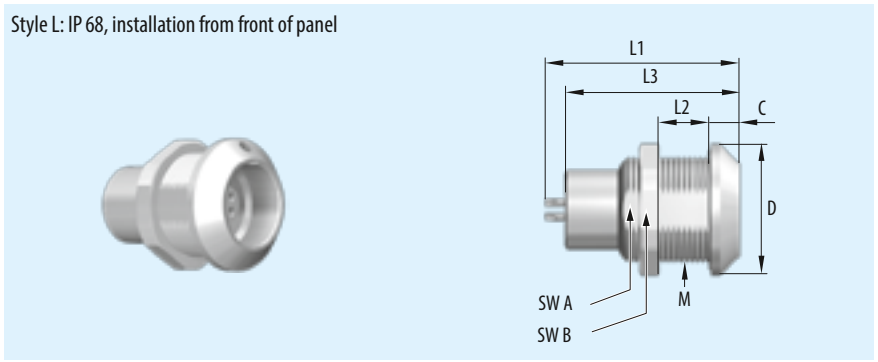

Size	Dimensions in mm								Panel cut-out		
	L1 <sup>1)</sup>	L2	L3 <sup>2)</sup>	M	D	C	SW A	SW B	SW	Ø	
0	0	~ 24.0	~ 5.0	19.7	14×1	18.0	4.0	12.5	17	12.6	14.1
1	1	~ 32.0	~ 9.0	26.6	16×1	20.0	4.5	14.5	19	14.6	16.1
2	2	~ 34.0	~ 9.0	27.0	20×1	25.0	5.0	18.5	24	18.6	20.1

<sup>1</sup> L1 = max. length incl. contact insert  
<sup>2</sup> L3 = length of housing

**Technical data**  
 – IP 68 in mated and unmated condition  
 – Anti-rotation feature  
 – Crimp contacts not possible  
 – Contact configuration see page 61.

Series K





## Details for the Part Number Key Series K

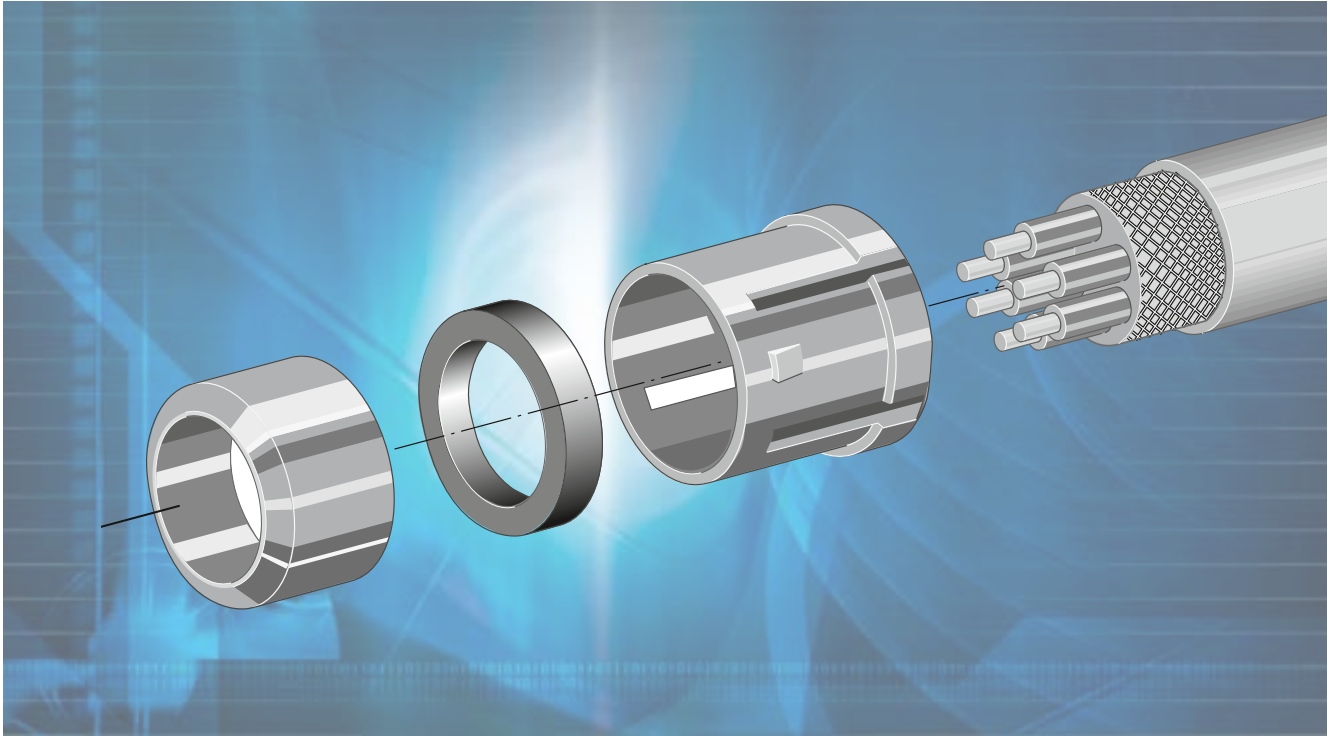

Series K



**Keyings**  
**Housing Materials**  
**Collet System**  
**Cable Bend Reliefs**

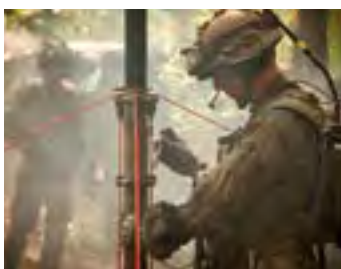

### Keying Possibilities

### Housing Material

Series K

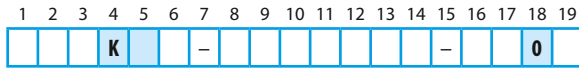

Angle	Keying	Receptacle front view	Keying				
			0	1	2	3	4
0°	<b>0</b>		●	●	●	●	●
30°	<b>A</b>		●	●	●	○	○
45°	<b>C</b>		●	●	●	○	○
60°	<b>F</b>		●	●	●	○	○
75°	<b>H</b>		○	○	○	○	○
95°	<b>K</b>		○	○	○	○	○
120°	<b>Q</b>		○	○	○	○	○
145°	<b>W</b>		○	○	○	○	○

● Standard  
○ On Request

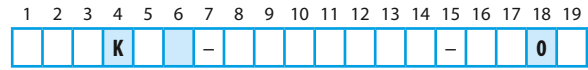

Housing material	Housing material	
	Standard	<b>C</b>
On request	<b>S</b>	Cu-alloy / black chromate

Special materials and surfaces on request.

### Collet System

1	2	3	4	5	6	7	8	9	10	11	12	13	14	15	16	17	18	19
			K			-								-				0

Cable diameter in mm	Size					16	17
	0	1	2	3	4		
> 1.0 – 1.5		●				1	5
> 1.5 – 2.0	●	●				2	0
> 2.0 – 2.5	●	●				2	5
> 2.5 – 3.0	●	●	●			3	0
> 3.0 – 3.5	●	●	●	●		3	5
> 3.5 – 4.0	●	●	●	●		4	0
> 4.0 – 4.5	●	●	●	●		4	5
> 4.5 – 5.0	●	●	●	●		5	0
> 5.0 – 5.5		●	●	●		5	5
> 5.5 – 6.0		●	●	●		6	0
> 6.0 – 6.5		●	●	●		6	5
> 6.5 – 7.0		●	●	●		7	0
> 7.0 – 7.5			●	●	●	7	5
> 7.5 – 8.0			●	●		8	0
> 8.0 – 8.5			●	●	●	8	5
> 8.5 – 9.0			●	●		9	0
> 9.0 – 9.5				●	●	9	5
> 9.5 – 10.0				●		0	1
> 10.0 – 10.5				●	●	0	2
> 10.5 – 11.5				●		0	3
> 13.5 – 14.0				●		1	4
Without collet system (on request)						0	0

Useable for all plugs and in-line receptacles and receptacles.

Application: Collet nut for strain relief.

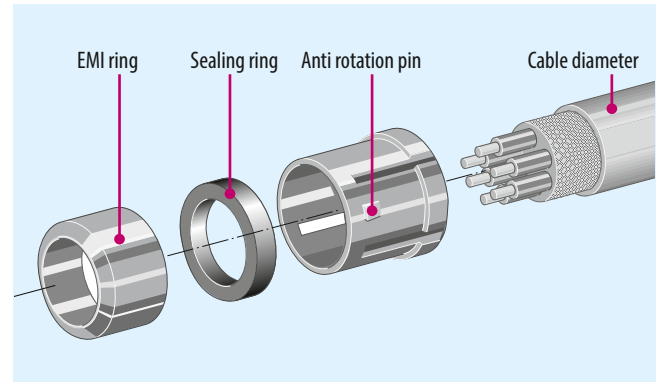

## Right-Angled Print Contacts in the Receptacle

1	2	3	4	5	6	7	8	9	10	11	12	13	14	15	16	17	18	19
			K			-				Q	0	0	-				0	0

Right-angled print contact

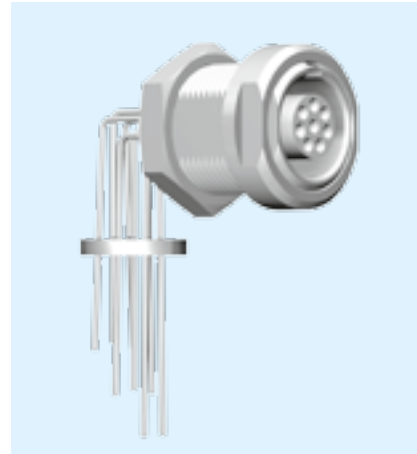

**Technical data**

- PCB layout see page 76
- Pin version on request.

## Definition of the Back Nut

1	2	3	4	5	6	7	8	9	10	11	12	13	14	15	16	17	18	19
			K			-								-				0

Standard back nut

0

Straight-angled Break-Away plugs, in-line receptacles, receptacles style 6 and 7



Back nut for silicone cable bend reliefs

S

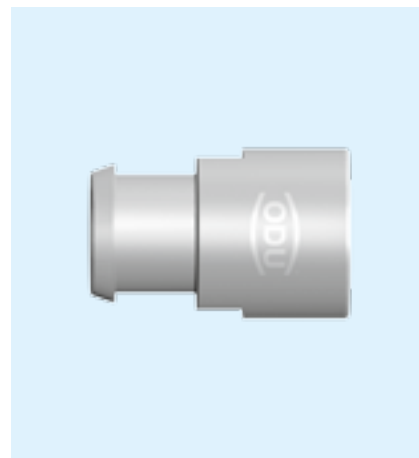

Cable bend reliefs see page [92](#).



## Series B, IP 68

### FP Locking Principle Keying with Pin and Groove



Series B



**Push-Pull Locking Principle FP**

Series B

Connector in **unmated** condition.

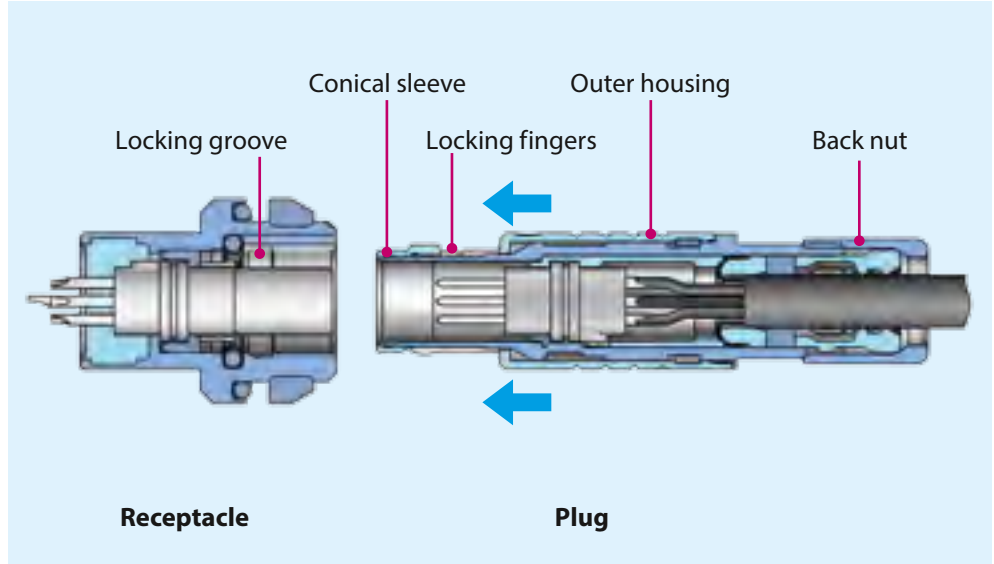

Connector in **mated** condition.

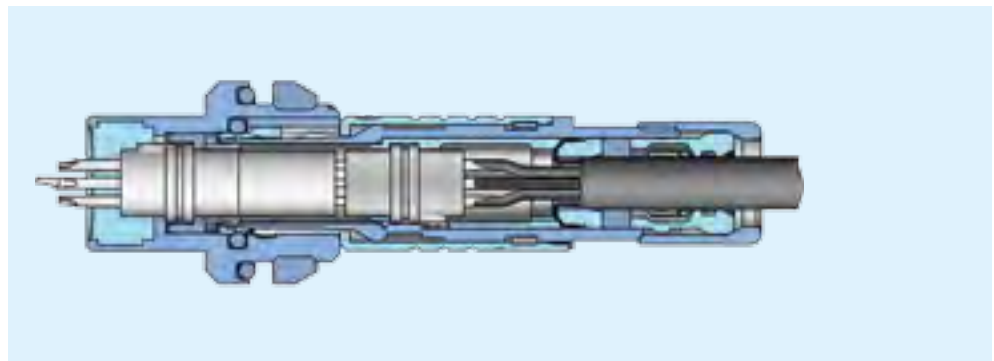

Pulling on the cable or on the back nut causes the locking fingers to grip tighter into the groove inside the receptacle. A separation is virtually impossible.

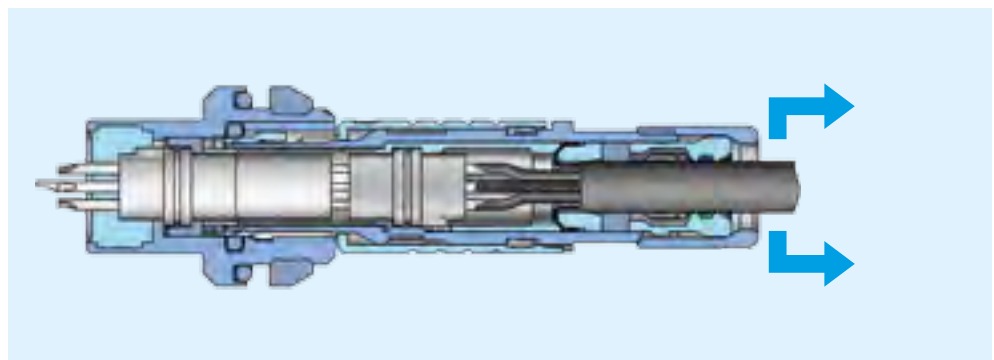

Pulling on the outer plug housing disengages the locking fingers from the receptacle groove and the connector separates easily.

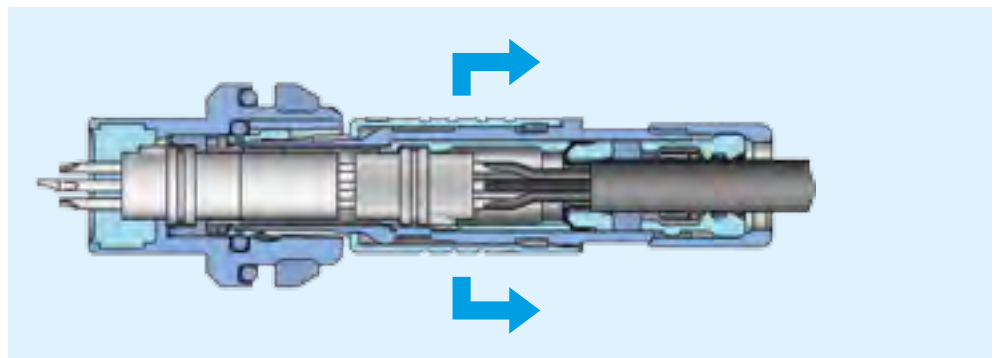



**ODU MINI-SNAP B**  
with FP Locking Scheme in Cross Section

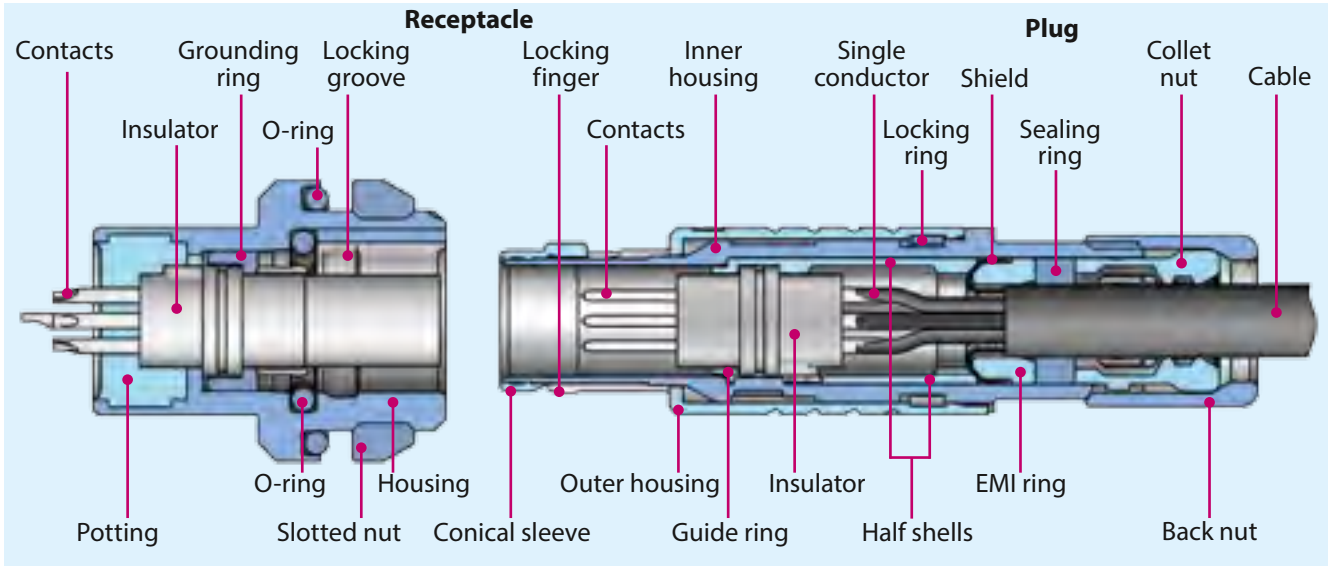

Series B

**Available Housing Sizes**

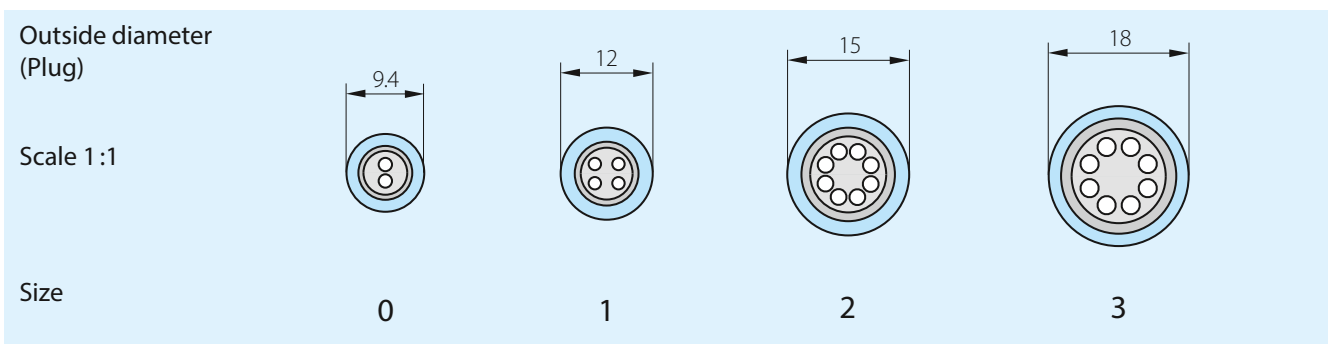

## Straight Plug

### Connector type

1	2	3	4	5	6	7	8	9	10	11	12	13	14	15	16	17	18	19
			B			-								-				0

S 3

Style 3: IP 68 with standard back nut

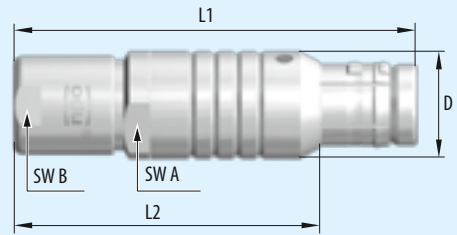

S 4

Style 4: IP 68 with back nut for cable bend relief<sup>1)</sup>

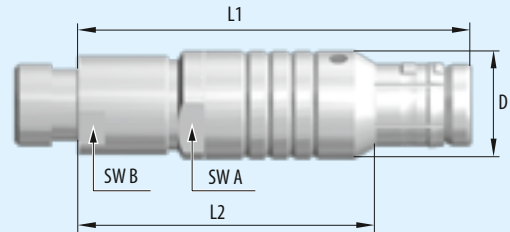

Size	Dimensions in mm					
	L1	L2	D	SW A	S3 SW B	S4 SW B
0	~ 40.0	~30.0	9.4	8	7	7
1	~ 49.0	~38.0	12.0	10	10	10
2	~ 53.0	~41.0	15.0	13	12	13
3	~ 61.0	~46.0	18.0	16	15	15

#### Technical data

– Contact configuration see page 61.

<sup>1</sup> Cable bend reliefs have to be ordered separately (see page 92).

## Right-Angled Plug

### Connector type

1	2	3	4	5	6	7	8	9	10	11	12	13	14	15	16	17	18	19
			B			-									-			0

W 3

Style 3: IP 68 with standard back nut

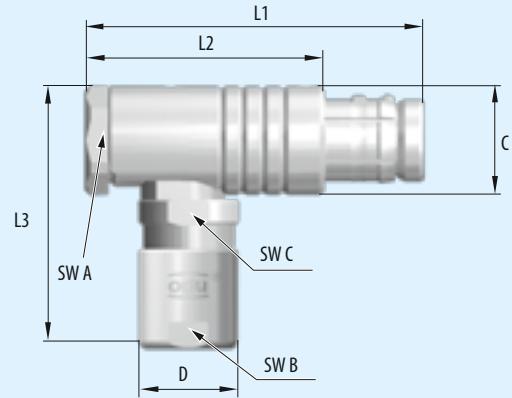

W 4

Style 4: IP 68 with back nut for cable bend relief<sup>1)</sup>

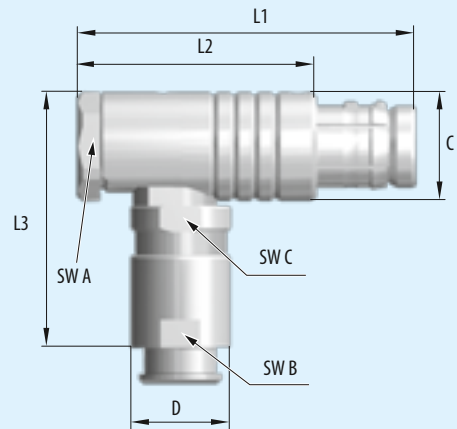

Size	Dimensions in mm									
	L1	L2	L3	C	D	SW A	W3 SW B	W4 SW B	SW C	
0	~ 34.3	24.3	~ 30.0	12.0	9.0	10	7	7	8	
1	~ 42.2	31.4	~ 32.0	12.5	11.0	11	10	10	10	
2	~ 46.3	34.2	~ 39.0	16.0	14.0	14	12	13	13	
3	~ 59.7	44.6	~ 41.0	18.0	17.0	16	15	15	16	

#### Technical data

- Contact configuration see page 61
- Assembly tool size 0: part number 700.412.106.000.000.

<sup>1)</sup> Cable bend reliefs have to be ordered separately (see page 92).

## In-Line Receptacle

Connect to Plug for Cable to Cable Connection

### Connector type

1	2	3	4	5	6	7	8	9	10	11	12	13	14	15	16	17	18	19
			B			-								-				0

Series B

**K 3**

Style 3: IP 68 with standard back nut

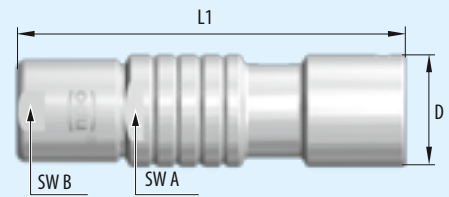
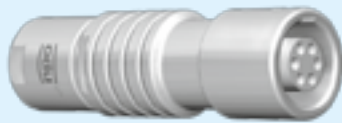

**K 4**

Style 4: IP 68 with back nut for cable bend relief<sup>1)</sup>

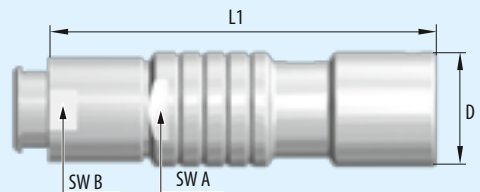
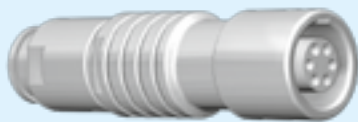

Size	Dimensions in mm					
	L1	D	SW A	K3 SW B	K4 SW B	
<b>0</b>	0	~ 39.0	10.0	8	7	7
<b>1</b>	1	~ 46.0	13.0	10	10	10
<b>2</b>	2	~ 50.0	16.0	13	12	13
<b>3</b>	3	~ 60.0	19.0	16	15	15

#### Technical data

– Contact configuration see page 61.

<sup>1)</sup> Cable bend reliefs have to be ordered separately (see page 92).

Receptacle

Connector type

1	2	3	4	5	6	7	8	9	10	11	12	13	14	15	16	17	18	19	
			B			-									-			0	0

G 2

Style 2: IP 68<sup>4)</sup>, installation from front of panel

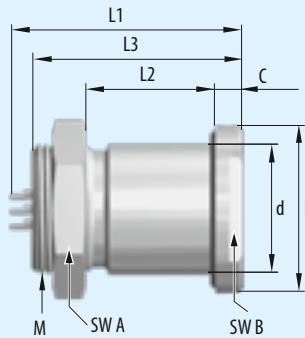
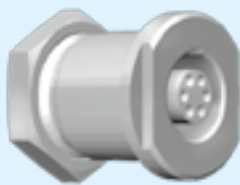

Blueprint panel cut-out

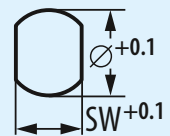

Size	Dimensions in mm									Panel cut-out Ø
	L1 <sup>1)</sup>	L2 <sup>3)</sup>	L3 <sup>2)</sup>	M	D	SW A	SW B	C	d	
0	~ 22.5	8.0	18.5	9×0.5	14.5	11.0	11.0	3.0	10.0	10.1
1	~ 27.0	13.0	22.5	14×1	18.0	17.0	14.0	3.0	14.0	14.1
2	~ 29.5	9.0	23.0	16×1	22.0	19.0	17.0	4.0	16.0	16.1
3	~ 32.0	12.0	26.5	20×1	26.0	25.0	24.0	4.0	20.0	20.1

- <sup>1</sup> L1 = max. length incl. contact insert
- <sup>2</sup> L3 = length of housing
- <sup>3</sup> Min. wallthickness without using a distance ring
- <sup>4</sup> Reference: potted receptacle see page 105 III.

Technical data

- IP 68 in mated and unmated condition
- Contact configuration and PCB layout see page 61
- Distance ring for wall-thickness adjustment see page 94
- No crimp contacts possible.

G 4

Style 4: IP 68<sup>3)</sup>, installation from front of panel with low rear profile

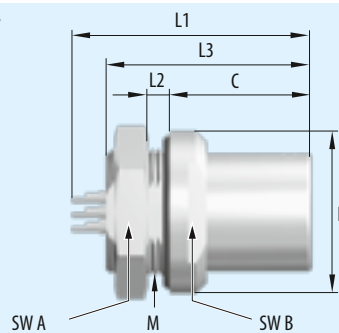
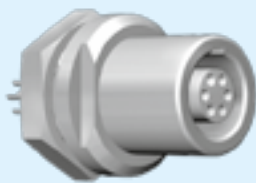

Blueprint panel cut-out

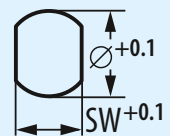

Size	Dimensions in mm									Panel cut-out	
	L1 <sup>1)</sup>	L2	L3 <sup>2)</sup>	M	D	SW A	SW B	C	SW	Ø	
0	~ 22.5	~ 4.0	18.5	9×0.5	14.5	11.0	12.0	12.0	8.3	9.1	
1	~ 27.0	~ 4.0	22.5	14×1	18.0	17.0	14.0	15.5	12.1	14.1	
2	~ 29.5	~ 4.5	23.0	16×1	21.0	19.0	17.0	15.5	13.6	16.1	
3	~ 32.0	~ 6.0	26.5	18×1	24.0	22.0	20.0	16.0	16.6	18.1	

Technical data

- IP 68 in mated and unmated condition
- Anti-rotation feature
- Contact configuration and PCB layout see page 61
- No crimp contacts possible.

- <sup>1</sup> L1 = max. length incl. contact insert
- <sup>2</sup> L3 = length of housing
- <sup>3</sup> Reference: potted receptacle see page 105 III.

Receptacle

Connector type

1	2	3	4	5	6	7	8	9	10	11	12	13	14	15	16	17	18	19	
			B			-								-				0	0

G 8

Style 8: IP 68<sup>3)</sup>, with slotted nut, installation from rear of panel

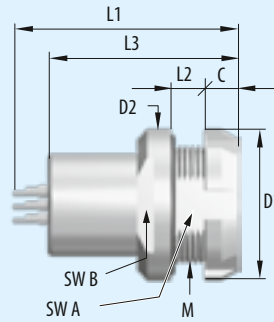
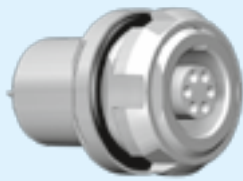

Blueprint panel cut-out

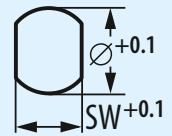

Size	Dimensions in mm										Panel cut-out	
	L1 <sup>1)</sup>	L2	L3 <sup>2)</sup>	M	D1	D2	C	SW A	SW B	SW	∅	
0	~ 22.5 ~ 3.5	18.5	10×0.5	15.0	14.5	3.0	9	12	9.1	10.1		
1	~ 27.0 ~ 4.0	22.5	14×1	18.0	18.0	4.0	12	14	12.1	14.1		
2	~ 29.5 ~ 3.0	23.0	16×1	22.0	21.0	5.0	15	18	15.1	16.1		
3	~ 32.0 ~ 6.0	26.5	20×1	25.0	26.0	5.0	18	-	18.1	20.1		

<sup>1</sup> L1 = max. length incl. contact insert

<sup>2</sup> L3 = length of housing

<sup>3</sup> Reference: Potted receptacle see page 105 III.

Technical data

- IP 68 in mated and unmated condition
- Anti-rotation feature
- Contact configuration and PCB layout see page 61
- No crimp contacts possible
- Nutdriver for slotted mounting nut see page 98.

G E

Style E: IP 68<sup>3)</sup>, installation from front of panel with low rear profile

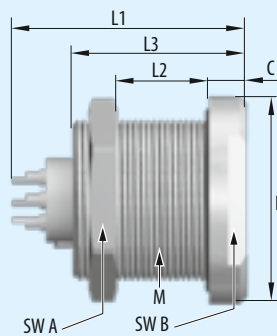
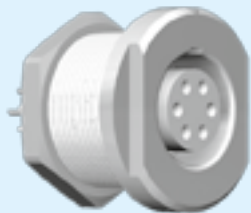

Blueprint panel cut-out

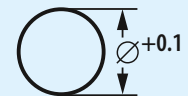

Size	Dimensions in mm								Panel cut-out	
	L1 <sup>1)</sup>	L2	L3 <sup>2)</sup>	M	D	SW A	SW B	C	∅	
0	~ 20.0 ~ 8.0	14.5	11×0.75	15.5	13	12	3.0	11.1		
1	~ 24.0 ~ 10.0	16.5	14×1	18.0	17	14	3.0	14.1		
2	~ 27.0 ~ 11.0	18.5	17×1	22.0	19	17	4.0	17.1		

<sup>1</sup> L1 = max. length incl. contact insert

<sup>2</sup> L3 = length of housing

<sup>3</sup> Reference: Tight receptacle see page 105 II.

Technical data

- IP 68 in mated condition
- Contact configuration and PCB layout see page 61.

## Details for the Part Number Key Series B

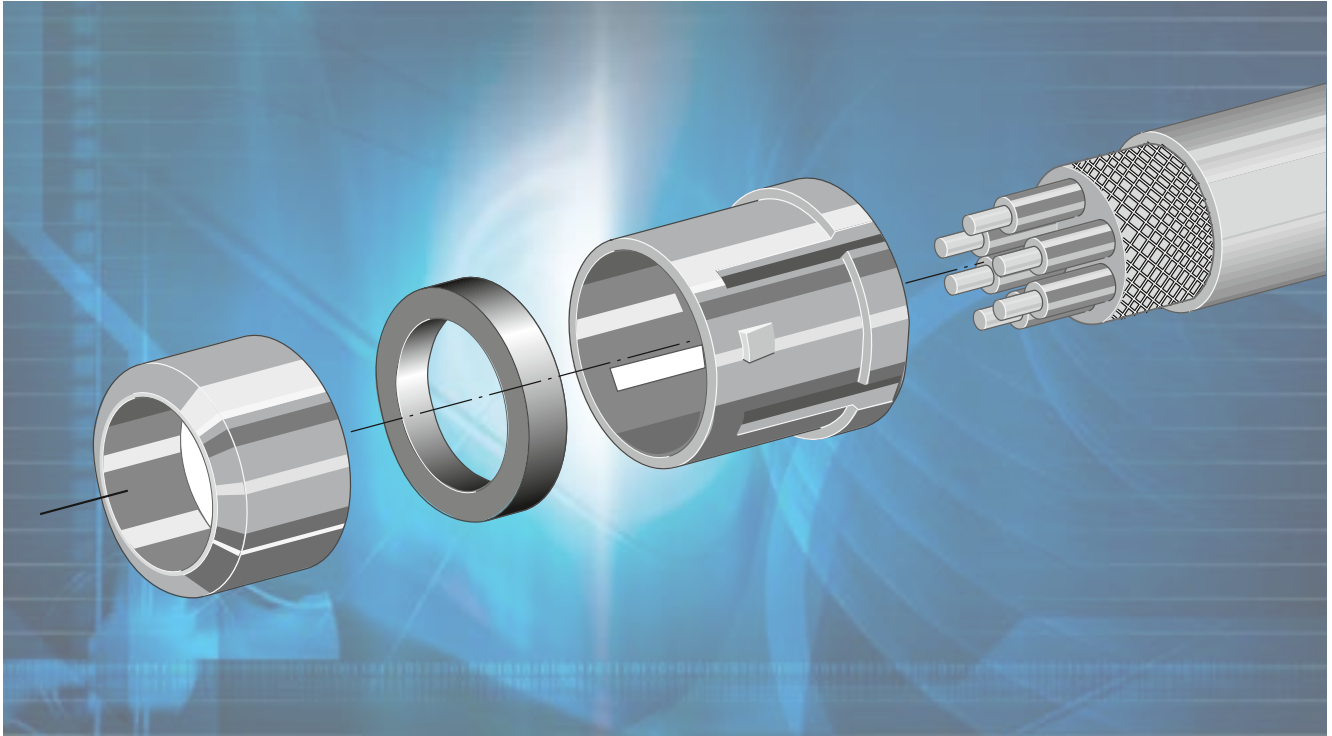

Series B



- Keyings**
- Housing Materials / Surfaces**
- Collet System**
- Cable Bend Reliefs**



### Keying Possibilities

### Housing Material

Series B

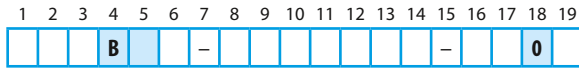

Angle	Keying	Receptacle front view	Size			
			0	1	2	3
0°	<b>0</b>		●	●	●	●
30°	<b>A</b>		●	●	●	●
37.5°	<b>B</b>				○	○
45°	<b>C</b>				●	●
-45°	<b>C</b>		●	●		
60°	<b>F</b>		●	●	●	●
75°	<b>H</b>				○	○
90°	<b>J</b>		○	○		○
95°	<b>K</b>				○	○
100°	<b>M</b>				○	○
120°	<b>Q</b>			○	○	○
125°	<b>T</b>					○
135°	<b>V</b>		○	○		○
145°	<b>W</b>		○	○	○	○
155°	<b>Y</b>		○	○		

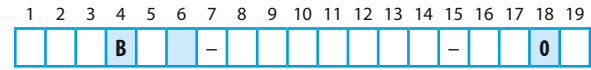

	Housing material	
Standard	<b>C</b>	Cu-alloy / matt chromate
On request	<b>S</b>	Cu-alloy / black chromate

Special materials and surfaces on request.

● Standard  
○ On request



### Collet System

1	2	3	4	5	6	7	8	9	10	11	12	13	14	15	16	17	18	19
			B			-								-				0

Cable diameter in mm	Size						
	0	1	2	3			
> 1.0 – 1.5		●			1	5	
> 1.5 – 2.0	●	●			2	0	
> 2.0 – 2.5	●	●			2	5	
> 2.5 – 3.0	●	●	●		3	0	
> 3.0 – 3.5	●	●	●	●	3	5	
> 3.5 – 4.0	●	●	●	●	4	0	
> 4.0 – 4.5	●	●	●	●	4	5	
> 4.5 – 5.0	●	●	●	●	5	0	
> 5.0 – 5.5		●	●	●	5	5	
> 5.5 – 6.0		●	●	●	6	0	
> 6.0 – 6.5		●	●	●	6	5	
> 6.5 – 7.0		●	●	●	7	0	
> 7.0 – 7.5			●	●	7	5	
> 7.0 – 8.0			●	●	8	0	
> 8.0 – 8.5			●	●	8	5	
> 8.5 – 9.0			●	●	9	0	
> 9.0 – 9.5				●	9	5	
> 9.5 – 10.0				●	0	1	
> 10.0 – 10.5				●	0	2	
Without collet system (on request)						0	0

Useable for all plugs and in-line receptacles.  
Application: **Collet nut** for strain relief.

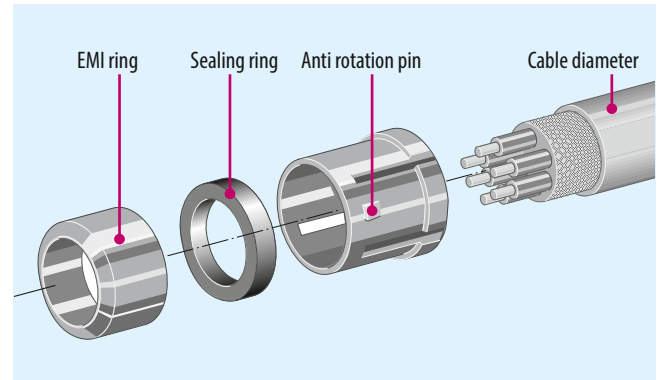

## Right-Angled Print Contacts in the Receptacle

1	2	3	4	5	6	7	8	9	10	11	12	13	14	15	16	17	18	19
			B			-				Q	0	0	-				0	0

Right-angled print contact

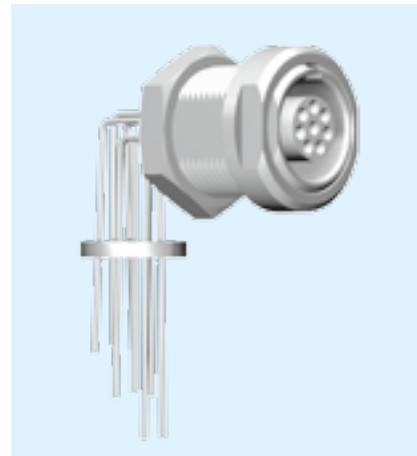

**Technical data**

- PCB layout see page 76
- Pin version on request.

## Definition of the Back Nut

1	2	3	4	5	6	7	8	9	10	11	12	13	14	15	16	17	18	19
			B			-								-				0

Standard back nut

0

Back nut for silicone cable bend reliefs

S

Straight-angled Break-Away plugs, in-line receptacles, receptacles style 6 and 7.

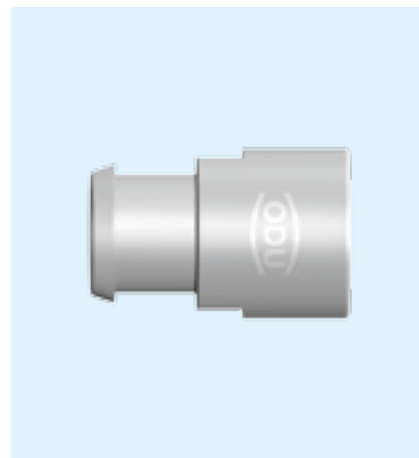

Cable bend reliefs see page [92](#).



Series B

## Inserts Series L, K, B



Inserts Series L, K, B



**PCB and solder contacts are factory-installed in the insulation body.**  
**Crimp contacts are shipped separately.**



## Insulation Body Material

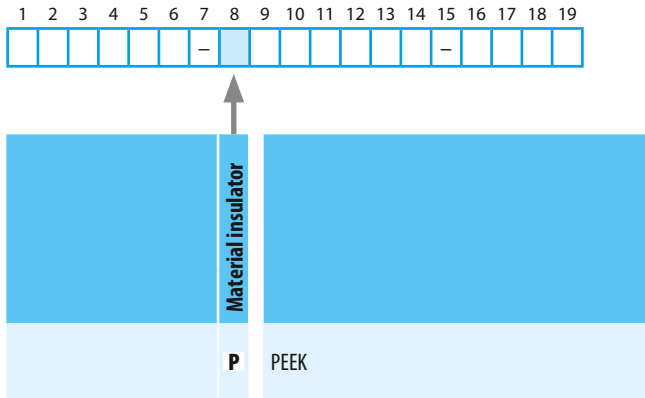

Further materials on request.

Inserts Series L, K, B

### Turned contacts

Termination	PEEK	
Solder	●	
Crimp	●	
PCB	●	

● Available

## Contact Configurations Size 00

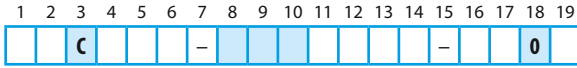

Size	Insulation body	Number of contacts	Contact diameter mm	Nominal current load per contact <sup>1)</sup> A	Clearance and creepage distance			Test voltage acc. SAE 13441 <sup>2)</sup> kVeff	Rated voltage <sup>5)</sup> kVrms	Termination			View on the termination side	
					Series	Contact to contact in mm	Series			Contact to housing in mm	Solder	Crimp <sup>3)</sup>	Print <sup>4)</sup>	Male contact side
C	P	0 2	0.5	5	L	0.6	L	0.8	1.100	0.366	●	●		
C	P	0 3	0.5	5	L	0.5	L	0.7	1.100	0.366	●	●		
C	P	0 4	0.5	5	L	0.4	L	0.6	0.900	0.300	●	●		

<sup>1)</sup> Derating factor see page 109.

<sup>2)</sup> SAE AS13441:1998 method 3001.1 (kVeff)

<sup>3)</sup> Tools for assembling see page 95.

<sup>4)</sup> PCB layout see page 75.

<sup>5)</sup> Maximal operating voltage at sea level up to 2.000 m acc. to SAE 13441. More information on page 110.

### Contact Configurations Size 0 (Part I)

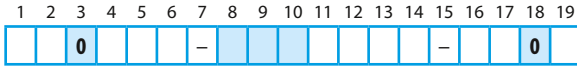

Inserts Series L, K, B

Size	Insulation body	Number of contacts	Contact diameter mm	Nominal current load per contact <sup>1)</sup> A	Clearance and creepage distance			Test voltage acc. SAE 13441 <sup>2)</sup> kVeff	Rated voltage <sup>5)</sup> kVrms	Termination			View on the termination side		
					Series	Contact to contact in mm	Series			Contact to housing in mm	Solder <sup>3)</sup>	Crimp <sup>3)</sup>	Print <sup>4)</sup>	Male contact side	Female contact side
0	P 0	2	0.9	10	L	1.0	L	1.0	1.500	0.500	●	●	●		
					K	1.0	K	0.9							
					B	1.0	B	1.0							
0	P 0	3	0.9	10	L	0.8	L	1.0	1.200	0.400	●	●	●		
					K	0.8	K	0.8							
					B	0.8	B	1.0							
0	P 0	4	0.7	7	L	0.8	L	1.0	0.900	0.300	●	●	●		
					K	0.8	K	0.8							
					B	0.8	B	1.0							
0	P 0	5	0.7	7	L	0.7	L	0.8	1.100	0.366	●	●	●		
					K	0.7	K	0.7							
					B	0.7	B	0.8							
0	P 0	6	0.5	5	L	0.7	L	0.8	0.900	0.300	●	●			
					K	0.7	K	0.7							
					B	0.7	B	0.8							

<sup>1</sup> Derating factor see page 109.  
<sup>2</sup> SAE AS13441:1998 method 3001.1 (kVeff)  
<sup>3</sup> Tools for assembling see page 95.  
<sup>4</sup> PCB layout see page 75.

<sup>5</sup> Maximal operating voltage at sea level up to 2.000 m acc. to SAE 13441.  
 More information on page 110.  
<sup>6</sup> Not compatible to the competitors. Position 14 of order number = 9.



**Contact Configurations  
Size 0 (Part II)**

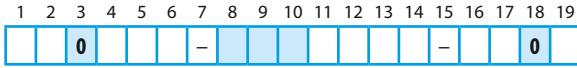

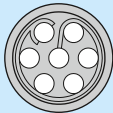
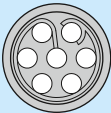
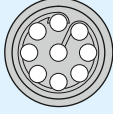
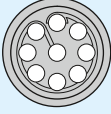
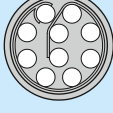
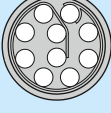
Size	Insulation body	Number of contacts	Contact diameter mm	Nominal current load per contact <sup>1)</sup> A	Clearance and creepage distance			Test voltage acc. SAE 13441 <sup>2)</sup> kVeff	Rated voltage <sup>5)</sup> kVrms	Termination			View on the termination side	
					Series	Contact to contact in mm	Series			Contact to housing in mm	Solder <sup>3)</sup>	Crimp <sup>3)</sup>	Print <sup>4)</sup>	Male contact side
0	P	0 7	0.5	5	L	0.7	L	0.8	0.900	0.300	●	●		
					K	0.7	K	0.7						
					B	0.7	B	0.8						
0	P	0 9	0.5	5	L	0.4	L	0.8	0.600	0.200	●	●		
					K	0.4	K	0.7						
					B	0.4	B	0.8						
0	P	1 0 <sup>6)</sup>	0.5	5	L	0.3	L	0.7	0.600	0.200	●	●		
					K	0.3	K	0.5						
					B	0.3	B	0.7						

**High speed inserts**

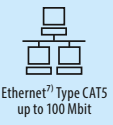
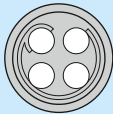
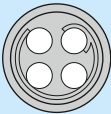
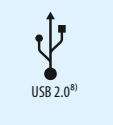
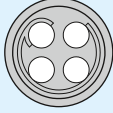
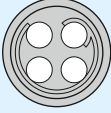
 Ethernet <sup>7)</sup> Type CAT5 up to 100 Mbit	P U 4	Male contact side	0.7	7	L	0.8	L	1.0	0.900	0.300	●	●	●		
					K	0.8	K	0.8							
 USB 2.0 <sup>8)</sup>	P O 4	Female contact side	0.7	7	L	0.8	L	1.0	0.900	0.300	●	●	●		
					K	0.8	K	0.8							
					B	0.8	B	1.0							

<sup>1)</sup> Derating factor see page 109.

<sup>2)</sup> SAE AS13441:1998 method 3001.1 (kVeff)

<sup>3)</sup> Tools for assembling see page 95.

<sup>4)</sup> PCB layout see page 75.

<sup>5)</sup> Maximal operating voltage at sea level up to 2.000 m acc. to SAE 13441.  
More information on page 110.

<sup>6)</sup> Not compatible to the competitors. Position 14 of order number = 9.

<sup>7)</sup> Acc. IEC 11801:2010. Additional information on request.

<sup>8)</sup> Acc. USB spec. rev. 2.0:2000. Additional information on request.

## Contact Configurations Size 1 (Part I)

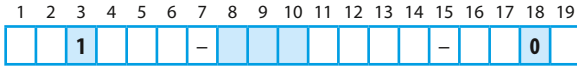

Inserts Series L, K, B

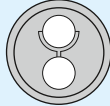
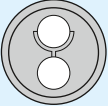
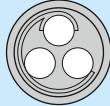
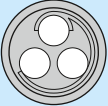
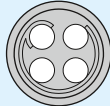
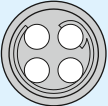
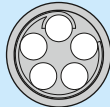
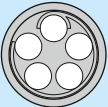
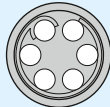
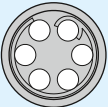
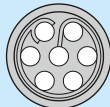
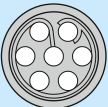
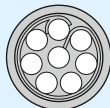
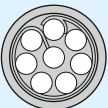
Size	Insulation body	Number of contacts	Contact diameter mm	Nominal current load per contact <sup>1)</sup> A	Clearance and creepage distance			Test voltage acc. SAE 13441 <sup>2)</sup> kVeff	Rated voltage <sup>5)</sup> kVrms	Termination			View on the termination side		
					Series	Contact to contact in mm	Series			Contact to housing in mm	Solder	Crimp <sup>3)</sup>	Print <sup>4)</sup>	Male contact side	Female contact side
1	P	0 2	1.3	14	L	1.3	L	1.4	1.650	0.550	●	●	●		
					K	1.3	K	1.0							
					B	1.3	B	1.4							
1	P	0 3	1.3	14	L	1.1	L	1.3	1.500	0.500	●	●	●		
					K	1.1	K	0.9							
					B	1.1	B	1.3							
1	P	0 4	0.9	10	L	1.0	L	1.4	1.500	0.500	●	●	●		
					K	1.0	K	1.1							
					B	1.0	B	1.4							
1	P	0 5	0.9	10	L	0.9	L	1.2	1.350	0.450	●	●	●		
					K	0.9	K	0.9							
					B	0.9	B	1.2							
1	P	0 6	0.7	7	L	0.9	L	1.2	1.200	0.400	●	●	●		
					K	0.9	K	0.9							
					B	0.9	B	1.2							
1	P	0 7	0.7	7	L	0.9	L	1.2	1.200	0.400	●	●	●		
					K	0.9	K	0.9							
					B	0.9	B	1.2							
1	P	0 8	0.7	7	L	0.6	L	1.1	1.000	0.333	●	●	●		
					K	0.6	K	0.8							
					B	0.6	B	1.1							

Continue next page

<sup>1</sup> Derating factor see page 109.

<sup>2</sup> SAE AS13441:1998 method 3001.1 (kVeff)

<sup>3</sup> Tools for assembling see page 95.

<sup>4</sup> PCB layout see page 78.

<sup>5</sup> Maximal operating voltage at sea level up to 2.000 m acc. to SAE 13441. More information on page 110.

## Contact Configurations Size 1 (Part II)

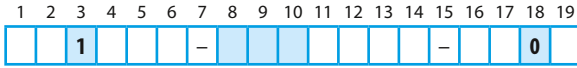

Size	Insulation body	Number of contacts	Contact diameter mm	Nominal current load per contact <sup>1)</sup> A	Clearance and creepage distance			Test voltage acc. SAE 13441 <sup>2)</sup> kVeff	Rated voltage <sup>5)</sup> kVrms	Termination			View on the termination side	
					Series	Contact to contact in mm	Series			Contact to housing in mm	Solder <sup>3)</sup>	Crimp <sup>3)</sup>	Print <sup>4)</sup>	Male contact side
1	P	1 0	0.5	5	L	0.5	L	1.2	1.000	0.333	●	●		
					K	0.5	K	0.9						
					B	0.5	B	1.2						
1	P	1 4	0.5	5	L	0.5	L	0.9	0.900	0.300	●	●		
					K	0.5	K	0.6						
					B	0.5	B	0.9						
1	P	1 6	0.5	5	L	0.4	L	0.9	0.900	0.300	●	●		
					K	0.4	K	0.6						
					B	0.4	B	0.9						

### High speed inserts

1		P	0 4	0.9	10	L	1.0	L	1.4	1.500	0.500	●	●	●		
						K	1.0	K	1.1							
						B	1.0	B	1.4							
1		P	D 8	0.5	5	L	0.5	L	1.0	1.000	0.333	●	●			
						K	0.5	K	0.7							
						B	0.5	B	1.0							

<sup>1</sup> Derating factor see page 109.

<sup>2</sup> SAE AS13441:1998 method 3001.1 (kVeff)

<sup>3</sup> Tools for assembling see page 95.

<sup>4</sup> PCB layout see page 78.

<sup>5</sup> Maximal operating voltage at sea level up to 2.000 m acc. to SAE 13441. More information on page 110.

<sup>6</sup> Acc. IEC 11801:2010. Additional information on request.

## Contact Configurations Size 2 (Part I)

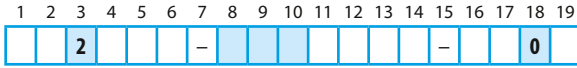

Inserts Series L, K, B

Size	Insulation body	Number of contacts	Contact diameter mm	Nominal current load <sup>1)</sup> A	Clearance and creepage distance			Test voltage acc. SAE 13441 <sup>2)</sup> kVeff	Rated voltage <sup>5)</sup> kVrms	Termination			View on the termination side		
					Series	Contact to contact in mm	Series			Contact to housing in mm	Solder	Crimp <sup>3)</sup>	Print <sup>4)</sup>	Male contact side	Female contact side
2	P	0 2	2.0	22	L	2.0	L	1.6	2.100	0.700	●	●			
					K	2.0	K	1.4							
					B	2.0	B	1.4							
2	P	0 3	1.6	17	L	1.9	L	1.7	2.100	0.700	●	●	●		
					K	1.9	K	1.5							
					B	1.9	B	1.6							
2	P	0 4	1.3	14	L	2.0	L	1.8	1.950	0.650	●	●	●		
					K	2.0	K	1.4							
					B	2.0	B	1.6							
2	P	0 5	1.3	14	L	1.6	L	1.7	1.800	0.600	●	●	●		
					K	1.6	K	1.3							
					B	1.6	B	1.5							
2	P	0 6	1.3	14	L	1.3	L	1.5	1.500	0.500	●	●	●		
					K	1.3	K	1.1							
					B	1.3	B	1.3							
2	P	0 7	1.3	14	L	1.3	L	1.4	1.800	0.600	●	●	●		
					K	1.3	K	1.0							
					B	1.3	B	1.2							
2	P	0 8	0.9	10	L	1.3	L	1.2	1.500	0.500	●	●	●		
					K	1.3	K	0.9							
					B	1.3	B	1.1							
2	P	1 0	0.9	10	L	1.0	L	1.2	1.500	0.500	●	●	●		
					K	1.0	K	0.9							
					B	1.0	B	1.1							

Continue next page

<sup>1)</sup> Derating factor see page 109.

<sup>2)</sup> SAE AS13441:1998 method 3001.1 (kVeff)

<sup>3)</sup> Tools for assembling see page 95.

<sup>4)</sup> PCB layout see page 80.

<sup>5)</sup> Maximal operating voltage at sea level up to 2.000 m acc. to SAE 13441. More information on page 110.

## Contact Configurations Size 2 (Part II)

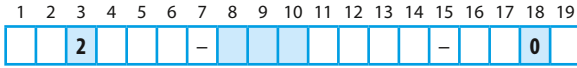

Size	Insulation body	Number of contacts	Contact diameter mm	Nominal current load <sup>1)</sup> A	Clearance and creepage distance			Test voltage acc. SAE 13441 <sup>2)</sup> kVeff	Rated voltage <sup>5)</sup> kVrms	Termination			View on the termination side		
					Series	Contact to contact in mm	Series			Contact to housing in mm	Solder <sup>3)</sup>	Crimp <sup>3)</sup>	Print <sup>4)</sup>	Male contact side	Female contact side
2	P	1 2	0.7	7	L	1.0	L	1.3	1.350	0.450	●	●	●		
					K	1.0	K	1.0							
					B	1.0	B	1.1							
2	P	1 4	0.7	7	L	0.9	L	1.2	1.200	0.400	●	●	●		
					K	0.9	K	0.9							
					B	0.9	B	1.1							
2	P	1 6	0.7	7	L	0.8	L	1.2	1.100	0.366	●	●	●		
					K	0.8	K	0.9							
					B	0.8	B	1.1							
2	P	1 8	0.7	7	L	0.7	L	1.2	0.900	0.300	●	●	●		
					K	0.7	K	0.9							
					B	0.7	B	1.1							
2	P	1 9	0.7	7	L	0.7	L	1.2	1.000	0.333	●	●	●		
					K	0.7	K	0.9							
					B	0.7	B	1.1							
2	P	2 6	0.5	5	L	0.6	L	1.1	0.900	0.300	●	●			
					K	0.6	K	0.8							
					B	0.6	B	1.0							

### High speed inserts

2		P	0 4	1.3	14	L	2.0	L	1.8	1.950	0.650	●	●	●		
						K	2.0	K	1.4							
						B	2.0	B	1.6							
2		P	D 8	0.9	10	L	1.1	L	1.3	1.500	0.500	●	●	●		
						K	1.1	K	1.0							
						B	1.1	B	1.1							

<sup>1</sup> Derating factor see page 109.

<sup>2</sup> SAE AS13441:1998 method 3001.1 (kVeff)

<sup>3</sup> Tools for assembling see page 95.

<sup>4</sup> PCB layout see page 80.

<sup>5</sup> Maximal operating voltage at sea level up to 2.000 m acc. to SAE 13441. More information on page 110.

<sup>6</sup> Acc. IEC 11801:2010. Additional information on request.

### Contact Configurations Size 3 (Part I)

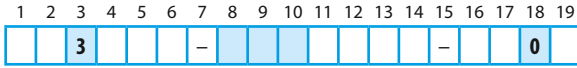

Inserts Series L, K, B

Size	Insulation body	Number of contacts	Contact diameter mm	Nominal current load per contact <sup>1)</sup> A	Clearance and creepage distance			Test voltage acc. SAE 13441 <sup>2)</sup> kVeff	Rated voltage <sup>5)</sup> kVrms	Termination			View on the termination side	
					Series	Contact to contact in mm	Series			Contact to housing in mm	Solder	Crimp <sup>3)</sup>	Print <sup>4)</sup>	Male contact side
3	P 0	3	2.0	22	L	2.4	L	2.1	1.800	0.600	●	●		
					K	2.4	K	1.8						
					B	2.4	B	2.1						
3	P 0	4	2.0	22	L	2.0	L	1.8	1.650	0.550	●	●		
					K	2.0	K	1.5						
					B	2.0	B	1.8						
3	P 0	7	1.6	17	L	1.5	L	1.6	1.800	0.600	●	●		
					K	1.5	K	1.3						
					B	1.5	B	1.6						
3	P 0	8	1.3	14	L	1.4	L	1.6	1.650	0.550	●	●		
					K	1.4	K	1.2						
					B	1.4	B	1.6						
3	P 1	0	1.3	14	L	1.2	L	1.4	1.350	0.450	●	●		
					K	1.2	K	1.0						
					B	1.2	B	1.4						
3	P 1	4	0.9	10	L	1.2	L	1.4	1.350	0.450	●	●		
					K	1.2	K	1.1						
					B	1.2	B	1.4						
3	P 1	6	0.9	10	L	1.1	L	1.3	1.350	0.450	●	●		
					K	1.1	K	1.0						
					B	1.1	B	1.3						

Continue next page

<sup>1</sup> Derating factor see page 109.  
<sup>2</sup> SAE AS13441:1998 method 3001.1 (kVeff)  
<sup>3</sup> Tools for assembling see page 95.  
<sup>4</sup> PCB layout see page 82.

<sup>5</sup> Maximal operating voltage at sea level up to 2.000 m acc. to SAE 13441. More information on page 110.

## Contact Configurations Size 3 (Part II)

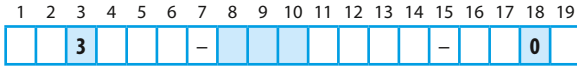

Size	Insulation body	Number of contacts	Contact diameter mm	Nominal current load per contact <sup>1)</sup> A	Clearance and creepage distance			Test voltage acc. SAE 13441 <sup>2)</sup> kVeff	Rated voltage <sup>5)</sup> kVrms	Termination			View on the termination side		
					Series	Contact to contact in mm	Series			Contact to housing in mm	Solder	Crimp <sup>3)</sup>	Print <sup>4)</sup>	Male contact side	Female contact side
3	P	1 8	0.9	10	L	1.0	L	1.2	1.350	0.450	●	●	●		
					K	1.0	K	0.9							
					B	1.0	B	1.2							
3	P	2 0	0.7	7	L	0.9	L	1.3	1.100	0.366	●	●	●		
					K	0.9	K	1.0							
					B	0.9	B	1.3							
3	P	2 2	0.7	7	L	0.9	L	1.2	1.100	0.366	●	●	●		
					K	0.9	K	1.9							
					B	0.9	B	1.2							
3	P	2 6	0.7	7	L	0.7	L	1.1	1.000	0.333	●	●	●		
					K	0.7	K	0.8							
					B	0.7	B	1.1							
3	P	3 0	0.7	7	L	0.6	L	1.2	0.900	0.300	●	●	●		
					K	0.6	K	0.9							
					B	0.6	B	1.2							

<sup>1</sup> Derating factor see page 109.

<sup>2</sup> SAE AS13441:1998 method 3001.1 (kVeff)

<sup>3</sup> Tools for assembling see page 95.

<sup>4</sup> PCB layout see page 82.

<sup>5</sup> Maximal operating voltage at sea level up to 2.000 m acc. to SAE 13441. More information on page 110.

## Contact Configurations Size 4

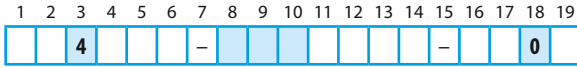

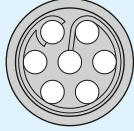
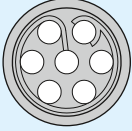
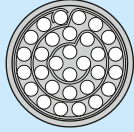
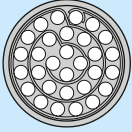
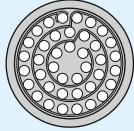
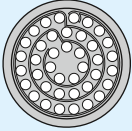
Size	Insulation body	Number of contacts	Contact diameter mm	Nominal current load per contact <sup>1)</sup> A	Clearance and creepage distance			Test voltage acc. SAE 13441 <sup>2)</sup> kVeff	Rated voltage <sup>5)</sup> kVrms	Termination			View on the termination side		
					Series	Contact to contact in mm	Series			Contact to housing in mm	Solder <sup>3)</sup>	Crimp <sup>3)</sup>	Print <sup>4)</sup>	Male contact side	Female contact side
4	P 0 7		2.0	22	L K	2.1 2.1	L K	2.2 1.6	1.650	0.550	●	●			
4	P 3 0		0.9	10	L K	0.8 0.8	L K	1.7 1.0	1.575	0.520	●	●			
4	P 4 0		0.7	7	L K	0.8 0.8	L K	1.7 1.0	1.000	0.333	●	●	●		

Inserts Series L, K, B

<sup>1</sup> Derating factor see page 109.

<sup>2</sup> SAE AS13441:1998 method 3001.1 (kVeff)

<sup>3</sup> Tools for assembling see page 95.

<sup>4</sup> PCB layout see page 84.

<sup>5</sup> Maximal operating voltage at sea level up to 2.000 m acc. to SAE 13441. More information on page 110.



### Contact Type / Surface

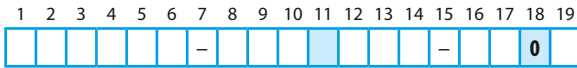

Termination	Contact type	Contact type/surface	Surface
Solder	Socket	<b>L</b>	0.75 µm Au (min.)
	Pin	<b>M</b>	0.75 µm Au (min.)
Crimp	Socket	<b>N</b>	0.75 µm Au (min.)
	Pin	<b>P</b>	0.75 µm Au (min.)
Print	Socket	<b>Q</b>	0.75 µm Au (min.)
	Pin	<b>R</b>	0.75 µm Au (min.)

## Contact Diameter Termination Cross Section

### Crimp contacts

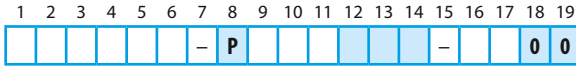

Size	Number of contacts	Contact diameter mm	Termination cross section		
			AWG	mm <sup>2</sup>	
0	4-5	0.7	F C O	28-32 0.09-0.04	
			F G O	22-26 0.38-0.15	
	2-3	0.9	J G O	22-26 0.38-0.15	
			J H O	20-24 0.50-0.25	
1	6-8	0.7	F C O	28-32 0.09-0.04	
			F G O	22-26 0.38-0.15	
	4-5	0.9	J G O	22-26 0.38-0.15	
			J H O	20-24 0.50-0.25	
	2-3	1.3	P L O	18-20 1.00-0.50	
			F C O	28-32 0.09-0.04	
	2	12-19	0.7	F G O	22-26 0.38-0.15
				J G O	22-26 0.38-0.15
8-10		0.9	J H O	20-24 0.50-0.25	
			P H O	20-24 0.50-0.25	
4-7		1.3	P L O	18-20 1.00-0.50	
			S L O	18-20 1.00-0.50	
3	3	1.6	S N O	18 1.50-1.00	
			S N O	14-16 1.50-1.00	
	2	2.0	T N O	18 1.50-1.00	
			T N O	14-16 1.50-1.00	
3	20-30	0.7	F C O	28-32 0.09-0.04	
			F G O	22-26 0.38-0.15	
	14-18	0.9	J G O	22-26 0.38-0.15	
			J H O	20-24 0.50-0.25	
	8-10	1.3	P H O	20-24 0.50-0.25	
			P L O	18-20 1.00-0.50	
	7	1.6	S L O	18-20 1.00-0.50	
			S N O	18 1.50-1.00	
			S N O	14-16 1.50-1.00	

### Solder contacts

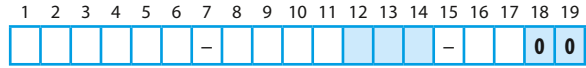

Contact diameter mm	Termination diameter mm	Termination cross section	
		AWG	mm <sup>2</sup>
0.5	0.4	C C O	28 0.08
0.7	0.6	F D O	26 0.15
0.7	0.85	F G O	22 0.38
0.9	0.85	J G O	22 0.38
1.3	1.1	P H O	20 0.50
1.6	1.4	S N O	18 1.00
2.0	1.85	T Q O	14 1.5
2.0	2.4	T S O	12 2.5
3.0	2.7	V T O	10 4.0

### PCB contacts

Contact diameter	Termination diameter	Termination cross section
0.5	0.5	C C O
0.7	0.5	F O O
0.9	0.7	J O O
1.3	0.7	P O O
1.6	0.7	S O O
2.0	0.7	T O O

### For mixed inserts<sup>1)</sup>



<sup>1)</sup> Please provide details of termination cross section!

### PCB Layout for Print Contacts Size 00

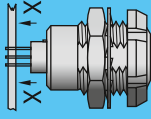
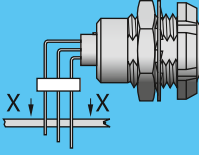
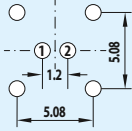
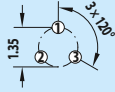
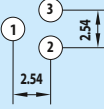
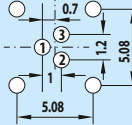
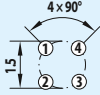
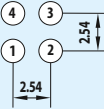
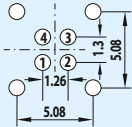
Positions	Straight	90° right-angled	Without thread	
2	Drill: 0.6 mm 	Drill: 0.6 mm 	Drill-contact: 0.6 mm Drill-mounting: 0.8 mm 	
3	Drill: 0.6 mm 	Drill: 0.6 mm 	Drill-contact: 0.6 mm Drill-mounting: 0.8 mm 	
4	Drill: 0.6 mm 	Drill: 0.6 mm 	Drill-contact: 0.6 mm Drill-mounting: 0.8 mm 	

The shown layouts are only considered with sockets in the receptacle.

Inserts Series L, K, B

### PCB Layout for Print Contacts Size 0 (Part I)

Inserts Series L, K, B

Positions	Straight	90° right-angled	Without thread	With thread
2	Drill: 0.8 mm 	Drill: 0.7 mm 	Drill-contact: 0.8 mm Drill-mounting: 0.8 mm 	Drill-contact: 0.8 mm Drill-mounting: 1.5 mm 
3	Drill: 0.8 mm 	Drill: 0.7 mm 	Drill-contact: 0.8 mm Drill-mounting: 0.8 mm 	Drill-contact: 0.8 mm Drill-mounting: 1.5 mm 
4	Drill: 0.6 mm Standard and high speed version 	Drill: 0.7 mm Standard and high speed version 	Drill-contact: 0.8 mm Drill-mounting: 0.8 mm Standard and high speed version 	Drill-contact: 0.8 mm Drill-mounting: 1.5 mm Standard and high speed version 
5	Drill: 0.6 mm 	Drill: 0.7 mm 	Drill-contact: 0.8 mm Drill-mounting: 0.8 mm 	Drill-contact: 0.8 mm Drill-mounting: 1.5 mm 
6	Drill: 0.6 mm 	Drill: 0.7 mm 	Drill-contact: 0.8 mm Drill-mounting: 0.8 mm 	Drill-contact: 0.8 mm Drill-mounting: 1.5 mm 

The shown layouts are only considered with sockets in the receptacle.

## PCB Layout for Print Contacts Size 0 (Part II)

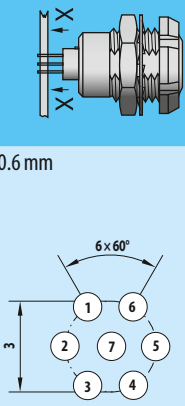
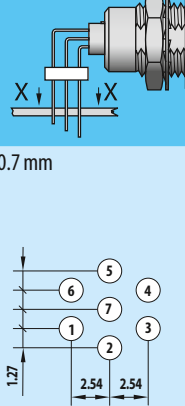
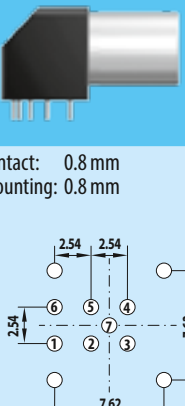
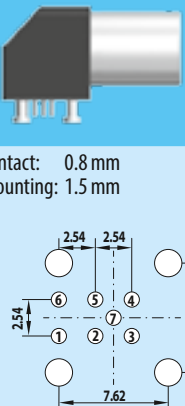
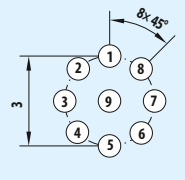
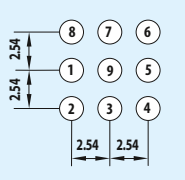
Positions	Straight	90° right-angled	Without thread	With thread
7	<p>Drill: 0.6 mm</p> 	<p>Drill: 0.7 mm</p> 	<p>Drill-contact: 0.8 mm Drill-mounting: 0.8 mm</p> 	<p>Drill-contact: 0.8 mm Drill-mounting: 1.5 mm</p> 
9	<p>Drill: 0.6 mm</p> 	<p>Drill: 0.6 mm</p> 		

The shown layouts are only considered with sockets in the receptacle.

**PCB Layout for Print Contacts  
Size 1 (Part I)**

Inserts Series L, K, B

	<b>Straight</b>	<b>90° right-angled</b>	<b>Without thread</b>	<b>With thread</b>
<b>Positions</b>				
<b>2</b>	Drill: 0.8 mm 	Drill: 0.9 mm 	Drill-contact: 0.8 mm Drill-mounting: 0.8 mm 	Drill-contact: 0.8 mm Drill-mounting: 1.5 mm 
<b>3</b>	Drill: 0.8 mm 	Drill: 0.9 mm 	Drill-contact: 0.8 mm Drill-mounting: 0.8 mm 	Drill-contact: 0.8 mm Drill-mounting: 1.5 mm 
<b>4</b>	Drill: 0.6 mm Standard and high speed version 	Drill: 0.7 mm Standard and high speed version 	Drill-contact: 0.8 mm Drill-mounting: 0.8 mm Standard and high speed version 	Drill-contact: 0.8 mm Drill-mounting: 1.5 mm Standard and high speed version 
<b>5</b>	Drill: 0.8 mm 	Drill: 0.7 mm 	Drill-contact: 0.8 mm Drill-mounting: 0.8 mm 	Drill-contact: 0.8 mm Drill-mounting: 1.5 mm 
<b>6</b>	Drill: 0.6 mm 	Drill: 0.7 mm 	Drill-contact: 0.8 mm Drill-mounting: 0.8 mm 	Drill-contact: 0.8 mm Drill-mounting: 1.5 mm 

The shown layouts are only considered with sockets in the receptacle.

**PCB Layout for Print Contacts**  
**Size 1 (Part II)**

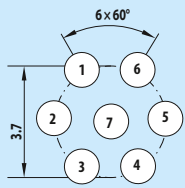
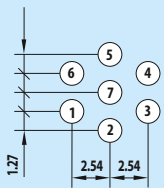
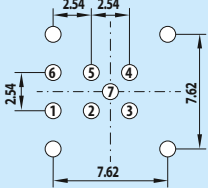
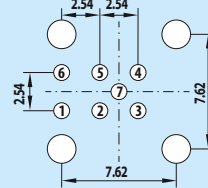
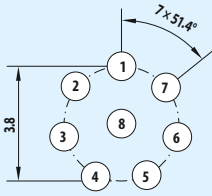
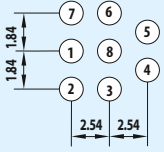
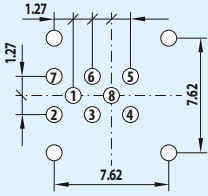
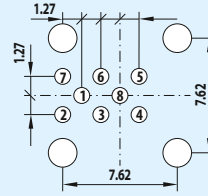
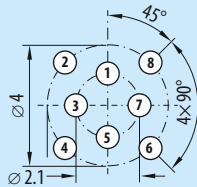
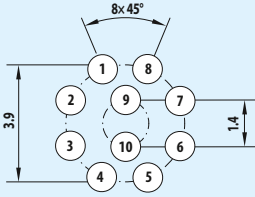
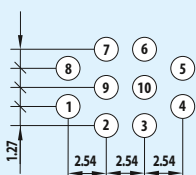
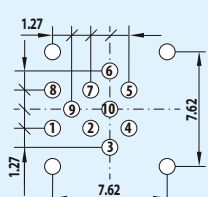
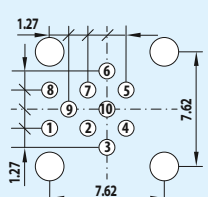
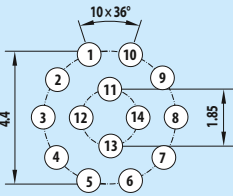
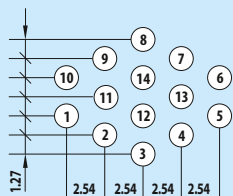
Positions	Straight	90° right-angled	Without thread	With thread
7	Drill: 0.6 mm 	Drill: 0.7 mm 	Drill-contact: 0.8 mm Drill-mounting: 0.8 mm 	Drill-contact: 0.8 mm Drill-mounting: 1.5 mm 
8	Drill: 0.6 mm Standard and high speed version 	Drill: 0.7 mm 	Drill-contact: 0.8 mm Drill-mounting: 0.8 mm 	Drill-contact: 0.8 mm Drill-mounting: 1.5 mm 
8	Drill: 0.6 mm Standard and high speed version 			
10	Drill: 0.6 mm 	Drill: 0.7 mm 	Drill-contact: 0.8 mm Drill-mounting: 0.8 mm 	Drill-contact: 0.8 mm Drill-mounting: 1.5 mm 
14	Drill: 0.6 mm 	Drill: 0.7 mm 		

Inserts Series L, K, B

The shown layouts are only considered with sockets in the receptacle.

**PCB Layout for Print Contacts  
Size 2 (Part I)**

Inserts Series L, K, B

	Straight	90° right-angled		Straight	90° right-angled
			<b>Positions</b>		
	Drill: 0.8 mm	Drill: 0.9 mm		Drill: 0.8 mm	Drill: 0.7 mm
3			7		
	Drill: 0.8 mm Standard and high speed version	Drill: 0.9 mm Standard and high speed version	8	Drill: 0.8 mm High speed version	Drill: 0.9 mm
4			8		
	Drill: 0.8 mm	Drill: 0.9 mm	8		
5			10	Drill: 0.8 mm	Drill: 0.7 mm
	Drill: 0.8 mm	Drill: 0.9 mm	12	Drill: 0.6 mm	Drill: 0.7 mm
6					

The shown layouts are only considered with sockets in the receptacle.

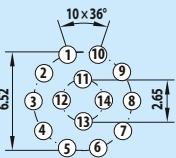
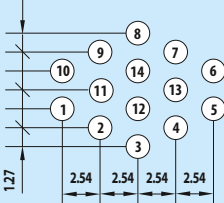
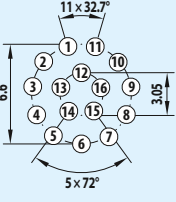
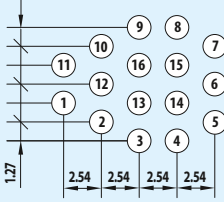
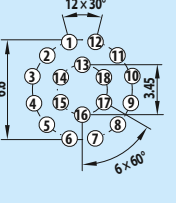
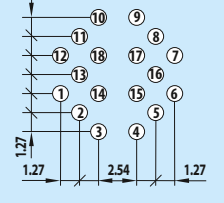
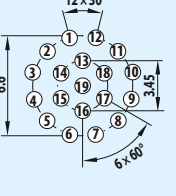
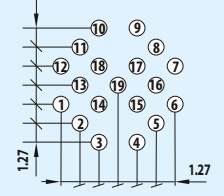

## PCB Layout for Print Contacts Size 2 (Part II)

Positions	Straight	90° right-angled
14	Drill: 0.6 mm 	Drill: 0.7 mm 
16	Drill: 0.6 mm 	Drill: 0.7 mm 
18	Drill: 0.6 mm 	Drill: 0.7 mm 
19	Drill: 0.6 mm 	Drill: 0.7 mm 

Inserts Series L, K, B

**PCB Layout for Print Contacts  
Size 3 (Part I)**

Inserts Series L, K, B

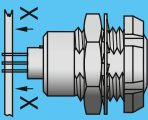
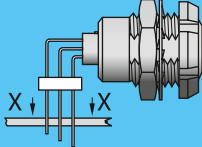
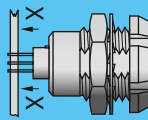
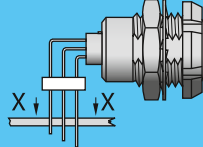
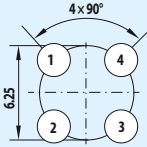
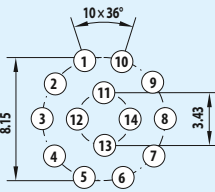
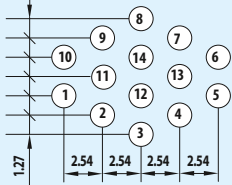
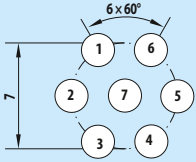
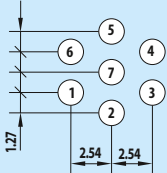
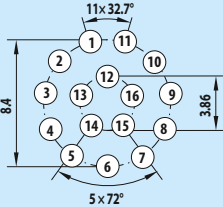
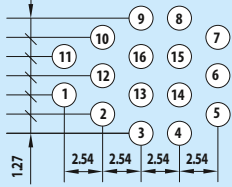
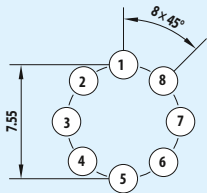
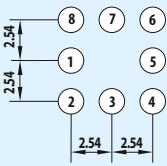
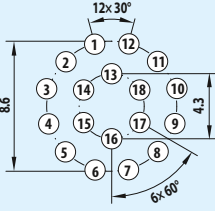
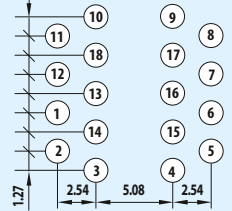
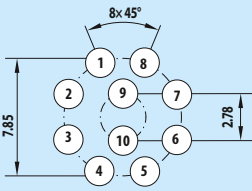
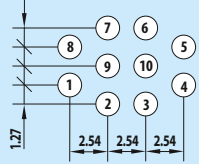
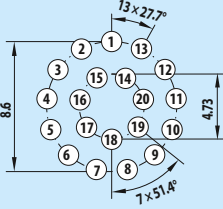
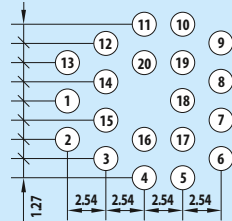
	Straight	90° right-angled		Straight	90° right-angled
<b>Positions</b>			<b>Positions</b>		
4	Drill: 0.8 mm 	Drill: 0.7 mm	14	Drill: 0.8 mm 	Drill: 0.7 mm 
7	Drill: 0.8 mm 	Drill: 0.9 mm 	16	Drill: 0.8 mm 	Drill: 0.7 mm 
8	Drill: 0.8 mm 	Drill: 0.9 mm 	18	Drill: 0.8 mm 	Drill: 0.7 mm 
10	Drill: 0.8 mm 	Drill: 0.9 mm 	20	Drill: 0.6 mm 	Drill: 0.7 mm 

The shown layouts are only considered with sockets in the receptacle.

## PCB Layout for Print Contacts Size 3 (Part II)

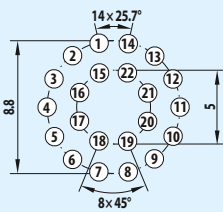
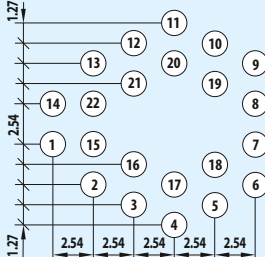
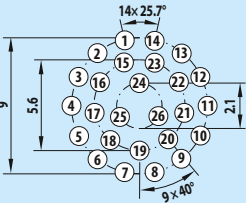
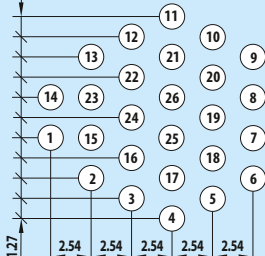
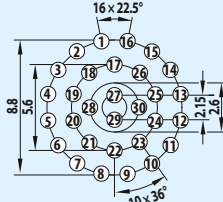
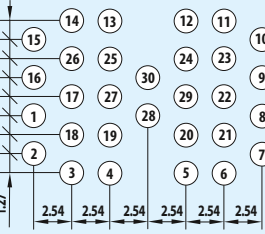
Positions	Straight	90° right-angled
22	<p>Drill: 0.6 mm</p> 	<p>Drill: 0.7 mm</p> 
26	<p>Drill: 0.6 mm</p> 	<p>Drill: 0.7 mm</p> 
30	<p>Drill: 0.6 mm</p> 	<p>Drill: 0.7 mm</p> 

## PCB Layout for Print Contacts Size 4

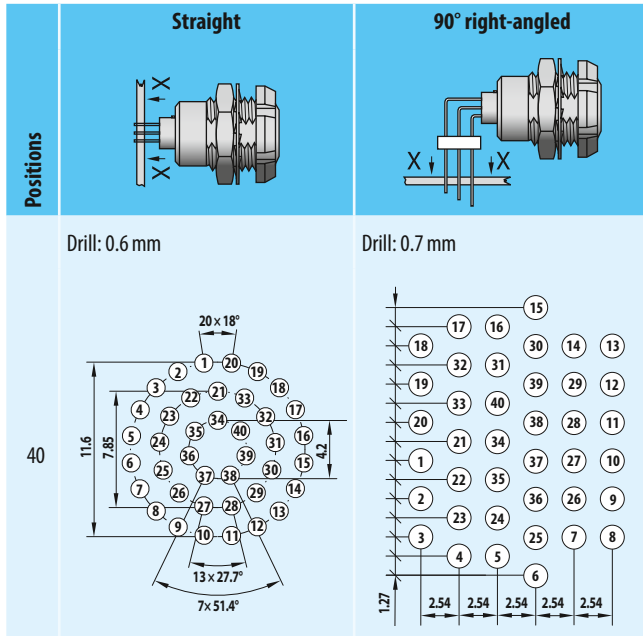

Inserts Series L, K, B

The shown layouts are only considered with sockets in the receptacle.

## Accessories

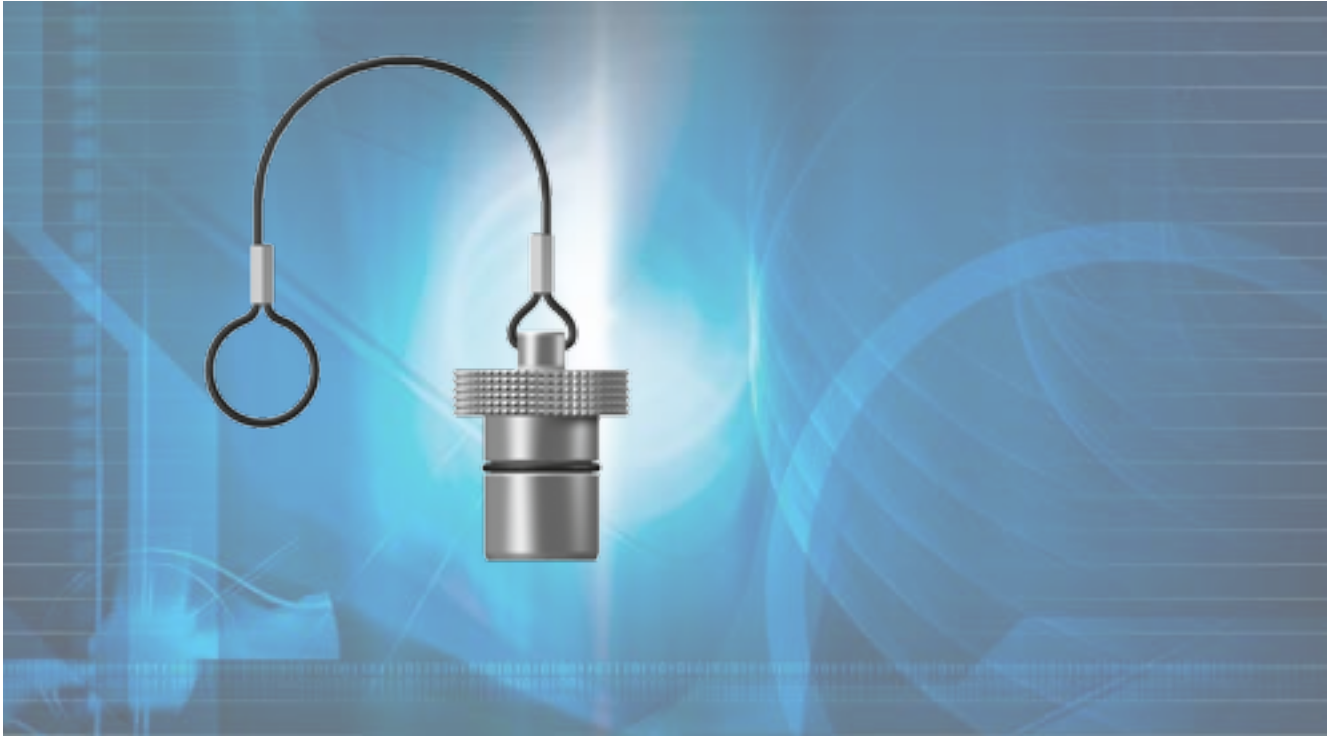

## Colour Coding Ring for Series L and B

### Size

Size	Part number with colour	∅ A	∅ B
00	713.422._.922.007	11.0	7.1
0	700.422._.922.009	13.5	9.1
0	700.422._.922.010	16.5	10.1
1	701.422._.922.012	17.0	12.1
1	701.422._.922.014	20.0	14.1
2	702.422._.922.015	22.0	15.1
2	702.422._.922.016	23.0	16.1
3	703.422._.922.018	25.0	18.1
3	703.422._.922.020	28.0	20.1

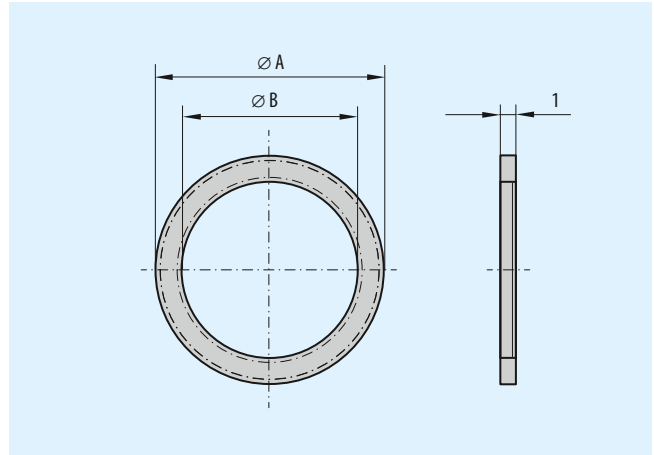

### Colours ↑ Please indicate colour code

Part number with colour	Colour	RAL-no. <sup>1)</sup> (similar)
... 202 ...	Red	3020
... 203 ...	White	9010
... 204 ...	Yellow	1016
... 205 ...	Green	6029
... 206 ...	Blue	5002
... 207 ...	Grey	7005
... 208 ...	Black	9005

<sup>1)</sup> Because of different raw materials the colours may slightly differ from RAL numbers.

### Mounting example

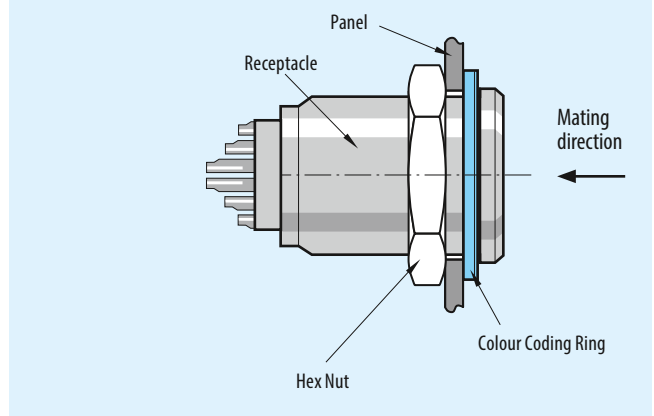

Accessories

### Order example

700.422.202.922.009  
 ↑            ↑            ↑  
 Size 0    Colour red    Housing ∅ M9

## Colour Coding Ring for Series L and B

### Size

Size	Part number with colour	SW A	SW B	∅ C	∅ D	∅ E	H	T	P <sub>max</sub>
00	713.423._922.007	8.0	6.4	7.1	10.0	8.8	1.8	1.0	4.0
0	700.423._922.009	9.9	8.3	9.1	12.0	10.8	1.8	1.0	6.0
0	700.423._922.010	10.7	9.1	10.1	16.5	11.8	1.8	1.0	1.5
1	701.423._922.012	12.2	10.6	12.1	16.0	13.8	1.8	1.0	6.0
1	701.423._922.014	13.7	12.1	14.1	21.0	15.8	1.8	1.0	2.0
2	702.423._922.015	16.2	13.6	15.1	21.0	17.8	2.2	1.2	7.5
2	702.423._922.016	17.7	15.1	16.1	23.0	18.8	2.2	1.2	0.6
3	703.423._922.018	20.2	16.6	18.2	25.0	21.8	2.2	1.2	10.5
3	703.423._922.020	21.7	18.1	20.2	28.0	23.8	2.2	1.2	3.5
4	704.423._922.025	27.2	23.7	25.2	32.0	28.8	2.5	1.5	10.0

**Colours** ↑ Please indicate colour code

Part number with colour	Colour	RAL-no. <sup>1)</sup> (similar)
... 202 ...	Red	3020
... 203 ...	White	9010
... 204 ...	Yellow	1016
... 205 ...	Green	6029
... 206 ...	Blue	5002
... 207 ...	Grey	7005
... 208 ...	Black	9005

<sup>1)</sup> Because of different raw materials the colours may slightly differ from RAL numbers.

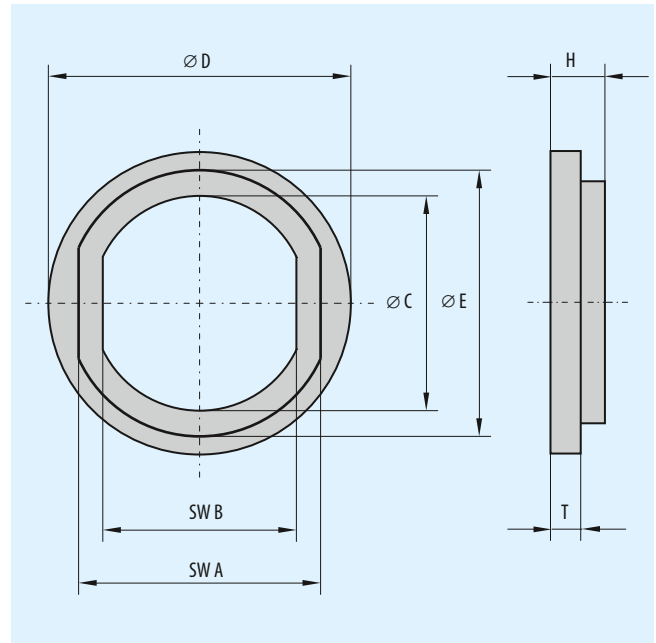

### Mounting example

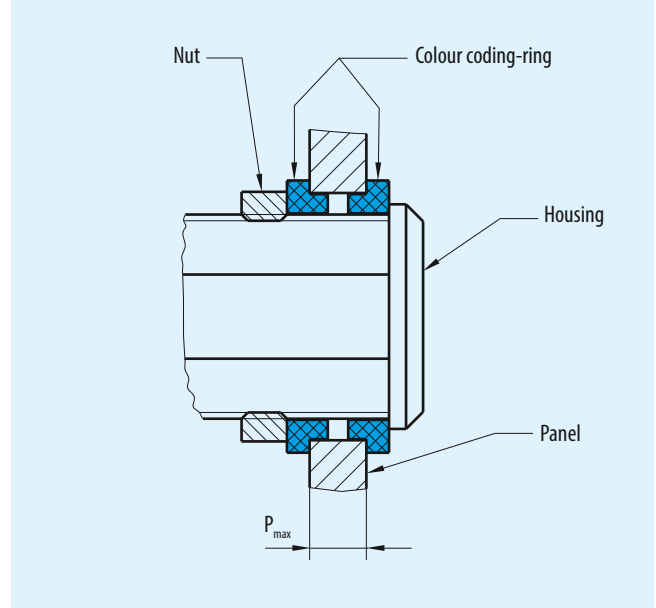

Accessories

### Order example

700.423.202.922.009  
 ↑            ↑            ↑  
 Size 0      Colour red      Housing ∅M9

## Hinged Cover for Series B and L

Suitable for all receptacle styles G1

Size	Part number	Dimensions in mm		
		A	B	∅ D
0	700.096.001.926.007	13.3	5.5	11.0
1	701.096.001.926.007	17.1	6.3	14.2
2	702.096.001.926.007	22.4	8.2	18.5
3	703.096.001.926.007	26.5	8.2	22.5

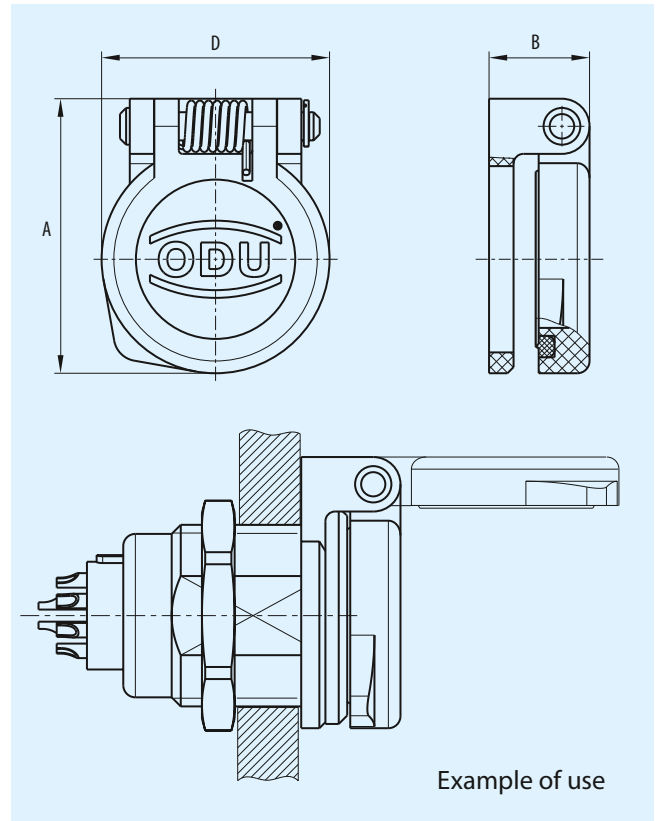



### Protective Covers for Receptacles (IP 50) in Series L

Size	Part number <sup>1)</sup>	A	Dimensions in mm		
			∅B	C	∅D
0	700.097.003.215._00	10.5	10.0	70.0	8.0
1	701.097.003.215._00	12.5	12.0	75.0	13.0
2	702.097.003.215._00	14.85	15.0	85.0	13.0
3	703.097.003.215._00	16.6	18.0	100.0	16.0
4	704.097.003.215._00	16.9	25.0	110.0	19.5

Surface: Matt chromate

- <sup>1)</sup> With \_ please, register desired lanyard material  
 0 = Polyamide lanyard with loop  
 1 = Stainless steel lanyard with loop  
 2 = Polyamide lanyard solder lug  
 3 = Stainless steel lanyard solder lug

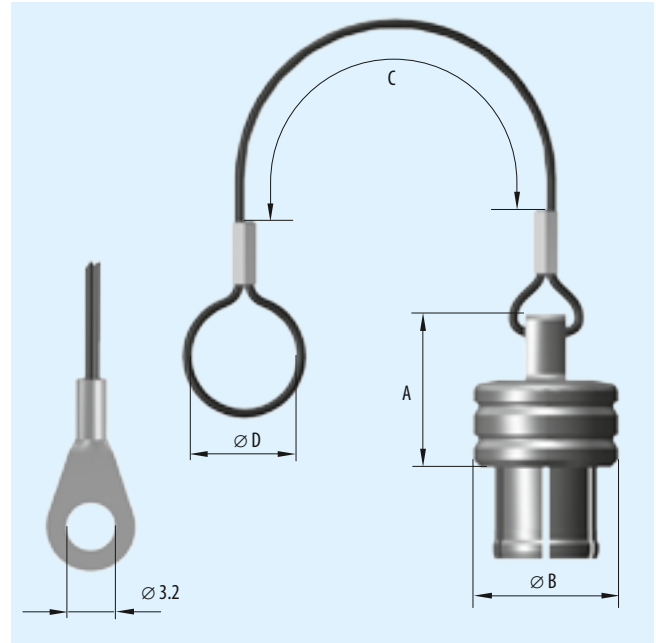

### Protective Covers for Plugs (IP 50) in Series L

Size	Part number <sup>1) 2)</sup>	A	Dimensions in mm		
			∅B	C	∅D
0	750.097.005.215.-0_	15.5	10.0	70.0	8.0
1	751.097.005.215.-0_	16.5	12.0	75.0	10.0
2	752.097.005.215.-0_	18.0	15.0	85.0	13.0
3	753.097.005.215.-0_	20.5	18.0	100.0	16.0

Surface: Matt chromate

- <sup>1)</sup> With - please, register desired lanyard material  
 0 = Polyamide lanyard with loop  
 1 = Stainless steel lanyard with loop  
 2 = Polyamide lanyard solder lug  
 3 = Stainless steel lanyard solder lug  
<sup>2)</sup> With \_ please, register desired coding (standard = 0)

Size	Codings (see page 24)										
	0	A	B	C	F	J	K	Q	V	W	Y
0	●	●		●	●	○			○	○	○
1	●	●		●	●	○			○	○	○
2	●	●	○	●	●		○	○		○	
3	●	●	○	●	●		○	○		○	

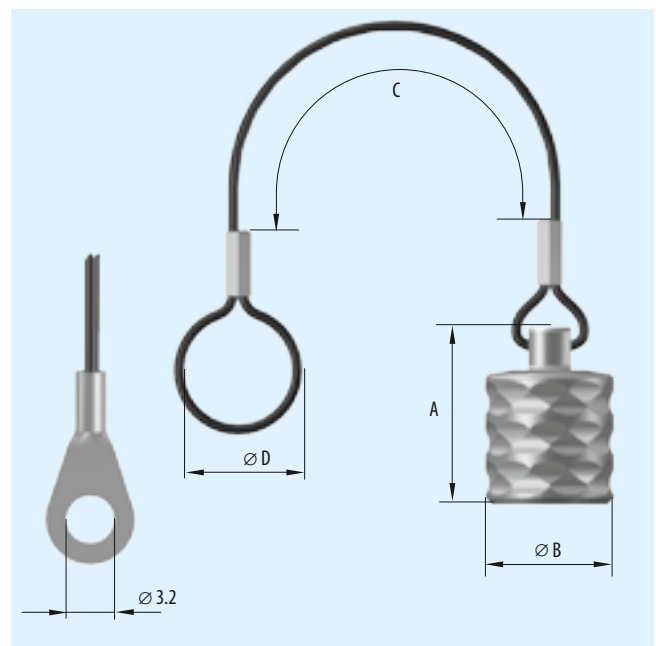

○ On request

**Protective Covers for Receptacles (IP 68) in Series K**

Size	Part number <sup>1)</sup>	A	Dimensions in mm		
			∅B	C	∅D
0	720.097.007.215._00	8.0	15.0	70	6
1	721.097.007.215._00	9.0	18.5	75	8
2	722.097.007.215._00	9.0	21.5	85	10
3	723.097.007.215._00	9.6	24.0	120	12
4	724.097.007.215._00	11.2	31.5	140	16

Surface: Matt chromate

- <sup>1</sup> With \_ please, register desired lanyard material  
 0 = Polyamide lanyard with loop  
 1 = Stainless steel lanyard with loop  
 2 = Polyamide lanyard solder lug  
 3 = Stainless steel lanyard solder lug

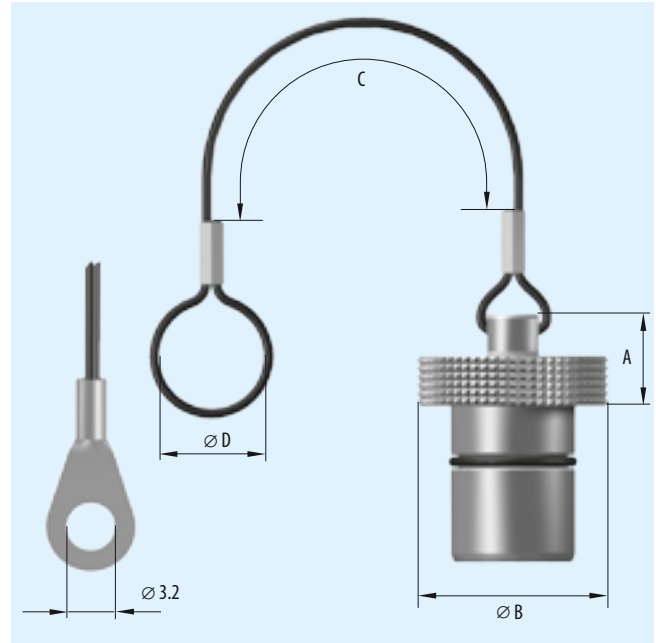

**Protective Covers for Plugs (IP 68) in Series K**

Accessories

Size	Part number <sup>1) 2)</sup>	A	Dimensions in mm		
			∅B	C	∅D
0	720.097.004.215.-0_	16.0	14	70	6
1	721.097.004.215.-0_	21.0	16	75	8
2	722.097.004.215.-0_	21.5	20	85	10
3	723.097.004.215.-0_	25.5	24	120	12
4	724.097.004.215.-0_	28	30	140	16

- <sup>1</sup> With - please, register desired lanyard material  
 0 = Polyamide lanyard with loop  
 1 = Stainless steel lanyard with loop  
 2 = Polyamide lanyard solder lug  
 3 = Stainless steel lanyard solder lug

Surface: Matt chromate

- <sup>2</sup> With \_ please, register desired coding (standard = 0)

Size	Codings (see page 42)									
	0	A	C	F	H	K	Q	W		
0	●	●	●	●						
1	●	●	●	●						
2	●	●	●	●						
3	●									
4	●									

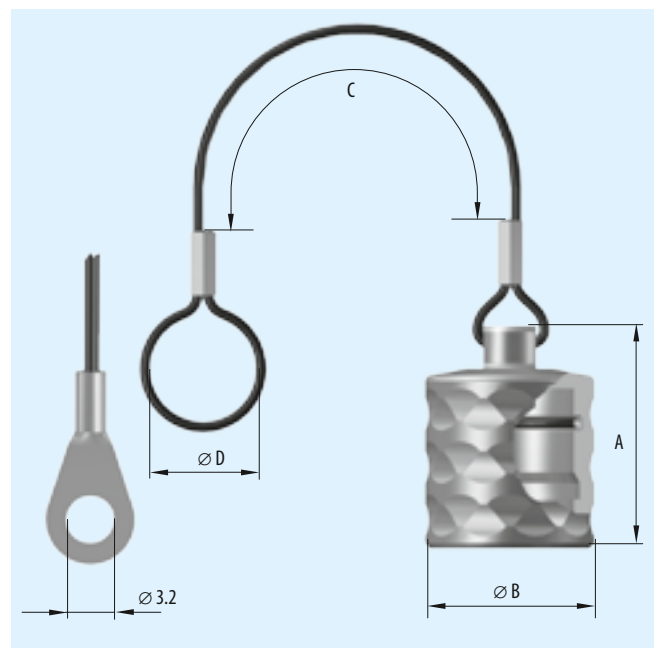

### Protective Covers for Receptacles (IP 68) in Series B

Size	Part number <sup>1)</sup>	A	Dimensions in mm		
			∅B	C	∅D
0	700.097.007.215_00	10	10	70	8
1	701.097.007.215_00	12	12	75	10
2	702.097.007.215_00	15	15	85	13
3	703.097.007.215_00	17	18	100	16

Surface: Matt chromate

- <sup>1</sup> With \_ please, register desired lanyard material  
 0 = Polyamide lanyard with loop  
 1 = Stainless steel lanyard with loop  
 2 = Polyamide lanyard solder lug  
 3 = Stainless steel lanyard solder lug

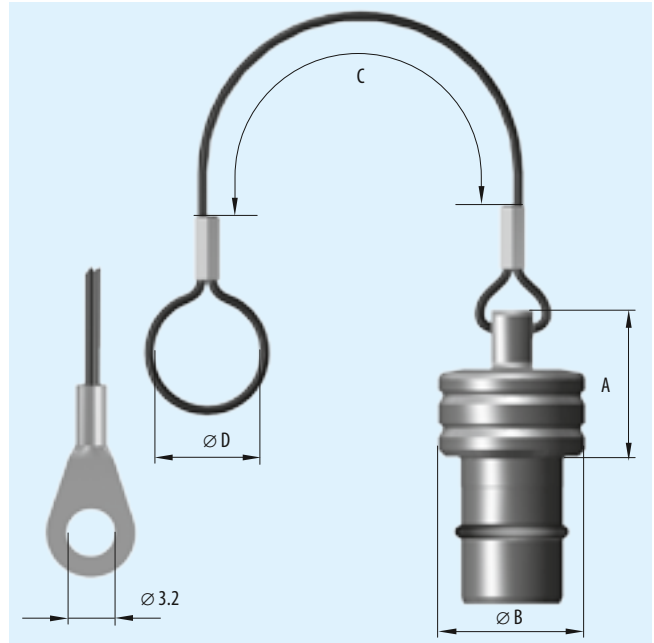

### Protective Covers for Plugs (IP 68) in Series B

Size	Part number <sup>1)</sup>	A	Dimensions in mm		
			∅B	C	∅D
0	700.097.004.215_00	15.5	10.5	70	8
1	701.097.004.215_00	16.5	13	75	10
2	702.097.004.215_00	18.5	16	85	13
3	703.097.004.215_00	21	19	100	16

Surface: Matt chromate  
 Protective covers for A5 and A6 on request.

- <sup>1</sup> With \_ please register desired lanyard material  
 0 = Polyamide lanyard with loop  
 1 = Stainless steel lanyard with loop  
 2 = Polyamide lanyard solder lug  
 3 = Stainless steel lanyard solder lug

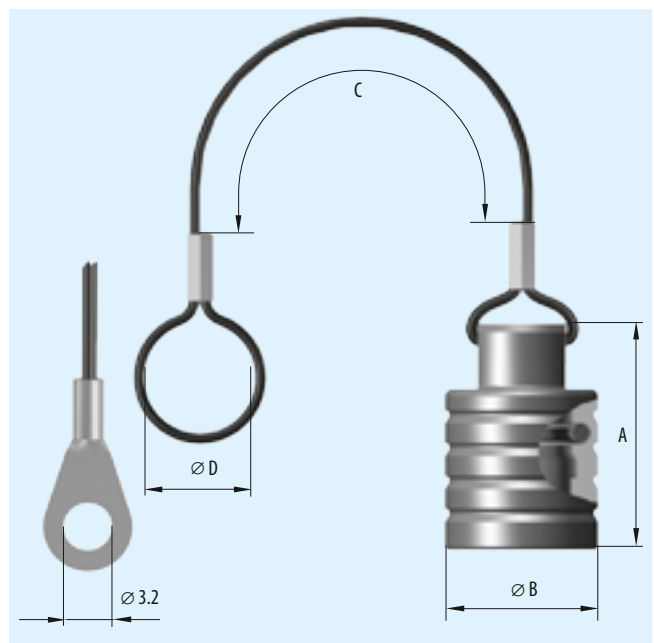

### Silicone Cable Bend Relief for All Series

Size	Part number	Dim. L	Cable (outer diameter)	
			min.	max.
00	713.023_...965.005	19	0.5	1.5
	713.023_...965.015		1.5	2.5
	713.023_...965.025		2.5	3.5
0	700.023_...965.020	27	2.0	2.5
	700.023_...965.025		2.5	3.0
	700.023_...965.030		3.0	3.5
	700.023_...965.035		3.5	4.0
	700.023_...965.040		4.0	4.5
	700.023_...965.045		4.5	5.0
	701.023_...965.025		2.5	3.0
1	701.023_...965.030	30	3.0	3.5
	701.023_...965.035		3.5	4.0
	701.023_...965.040		4.0	5.0
	701.023_...965.050		5.0	6.0
	701.023_...965.060		6.0	6.5
2	702.023_...965.070	36	6.5	7.5
	702.023_...965.030		3.0	3.5
	702.023_...965.035		3.5	4.0
	702.023_...965.040		4.0	5.0
	702.023_...965.050		5.0	6.0
	702.023_...965.060		6.0	7.0
3	702.023_...965.070	42	7.0	8.0
	702.023_...965.080		8.0	9.0
	703.023_...965.040		4.0	5.0
	703.023_...965.050		5.0	6.0
	703.023_...965.060		6.0	7.0
	703.023_...965.070		7.0	8.0
	703.023_...965.080		8.0	9.0
	703.023_...965.090		9.0	10.0
4	703.023_...965.100	60	10.0	11.0
	703.023_...965.110		11.0	12.0
	704.023_...965.080		8.0	10.0
	704.023_...965.100		10.0	12.0
	704.023_...965.120		12.0	14.0
	704.023_...965.140		14.0	16.0

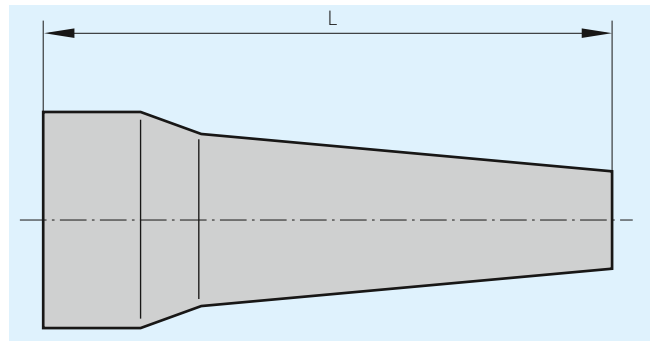

**Temperature range**

Silicone: -50° C up to +200° C, short-term up to +230° C, autoclavable

Accessories

**Colours**

Please indicate colour code

Colour code	Colour	RAL-no. <sup>1)</sup> (similar)
... 202 ...	Red	3020
... 203 ...	White	9010
... 204 ...	Yellow	1016
... 205 ...	Green	6029
... 206 ...	Blue	5002
... 207 ...	Grey	7005
... 208 ...	Black	9005

<sup>1)</sup> Because of different raw materials the colours may slightly differ from RAL numbers.

**Locking Washers for Series L and B**

**Solder Lugs for Series L and B**

Thread	Part number	Dimensions in mm		
		∅ A	∅ C	L
M7	945.000.001.000.057	9.5	7.1	1.0
M9	945.000.001.000.046	12.5	9.1	1.0
M12	945.000.001.000.047	16.0	12.1	1.1
M14	945.000.001.000.070	19.5	14.2	1.1
M15	945.000.001.000.048	19.5	15.1	1.1
M16	945.000.001.000.072	21.5	16.1	1.1
M18	945.000.001.000.049	25.0	18.1	1.1
M20	945.000.001.000.121	25.0	20.1	1.1
M25	945.000.001.000.086	32.0	25.1	1.4
M35	945.000.001.000.084	41.0	35.5	1.4

Thread	Part number	Dimensions in mm					
		∅ A	∅ B	C	D	∅ E	F
M7	713.140.246.301.000	7.4	10.0	17.0	4.0	1.8	0.3
M9	700.140.246.301.000	9.7	13.2	21.6	4.0	1.6	0.5
M12	701.140.246.301.000	12.2	17.0	27.5	4.0	1.6	0.5
M14	715.140.246.301.000	14.1	18.0	27.0	4.0	2.0	0.5
M15	702.140.246.301.000	15.2	20.0	32.0	4.0	1.6	0.5
M16	721.140.246.301.000	16.2	20.0	32.0	4.0	1.6	0.5
M18	703.140.246.301.000	18.2	25.0	39.0	4.0	1.6	0.5
M20	722.140.246.301.000	20.2	25.0	39.0	4.0	1.6	0.5
M25	704.140.246.301.000	25.6	35.0	51.0	5.0	2.1	0.6
M35	705.140.246.301.000	35.5	41.0	57.0	5.0	2.1	0.6

Nickel-plated surface

Silver-plated surface

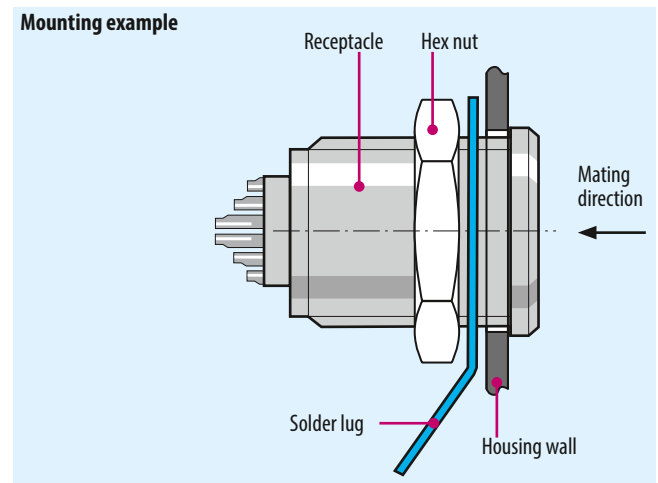
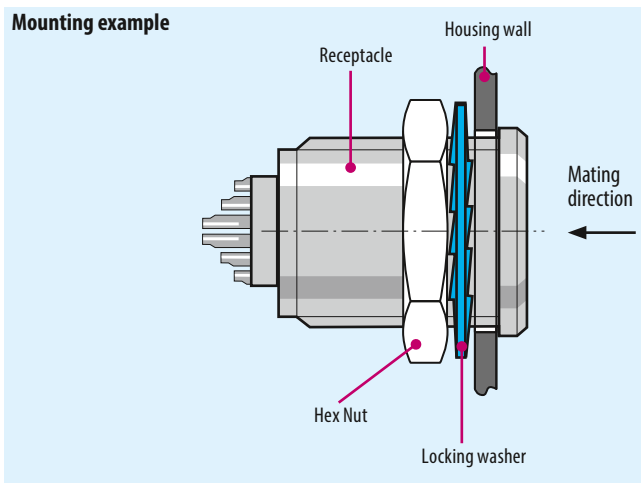
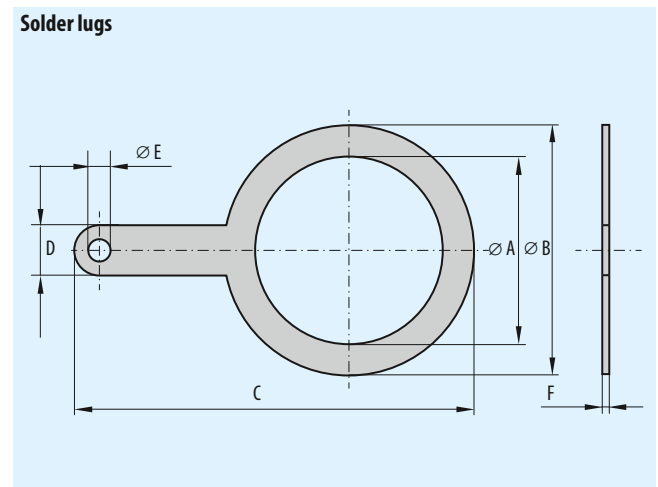
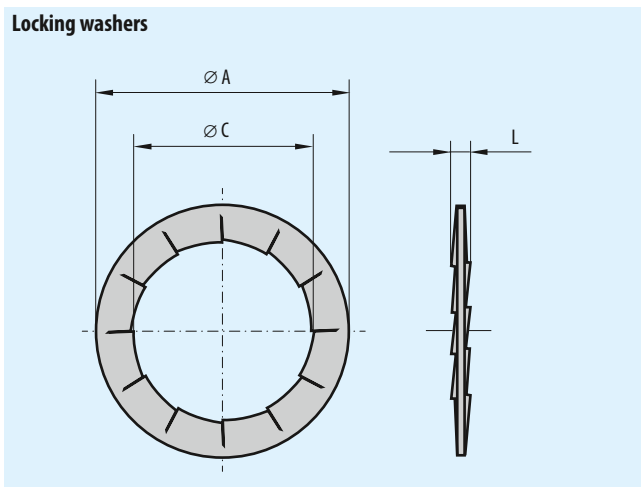

Accessories

### Distance Ring for Wall Thickness Adjustment for Style 2 in Series B<sup>1)</sup>

Size	Part number	Dimensions in mm			
		Da	Di	L	T
0	700.123.102.304.000	13.0	10.3	7.0	1–6
1	701.123.102.304.000	17.0	14.3	12.0	0.5–6
1	701.123.102.304.001	17.0	14.3	6.0	6–16
2	702.123.102.304.000	21.0	16.3	8.0	1–8
3	703.123.102.304.000	25.0	20.3	11.5	0.5–7

Material: brass  
Surface: nickel

<sup>1</sup> see page 53

### Backnut for Silicone Cable Bend Relief

Size	Part number <sup>2)</sup>	Dimensions in mm			Series		
		A	B	SW	L	K	B
00	713.022.117.3_000	6.0	6.4	5	●		
0	700.022.117.3_002	8.0	8.9	7	●	●	●
1	701.022.117.3_002	10.0	10.9	10	●	●	●
2	702.022.117.3_002	11.5	13.9	13	●	●	●
3	703.022.117.3_002	11.5	16.9	15			●
3	753.022.117.3_002	11.5	16.5	15	●	●	
4	704.022.117.3_002	15.0	23.0	20	●	●	●

In \_ please indicate surface finish:  
15 = Cu-alloy / matt chromate  
11 = Cu-alloy / black chromate  
04 = Cu-alloy / nickel

Accessories

Distance ring

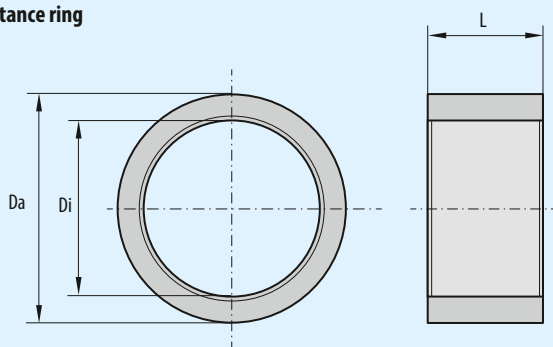

Mounting example

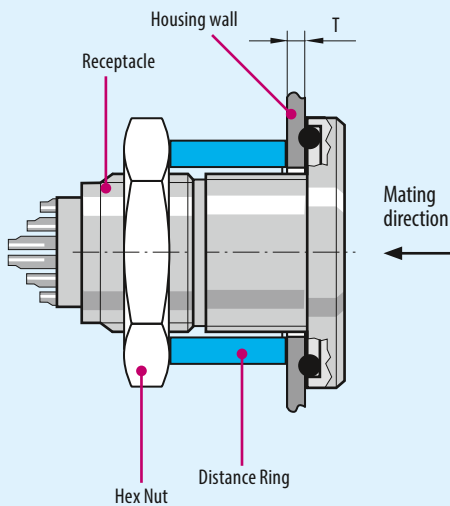

Backnut

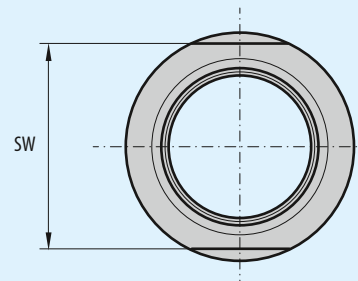

Mounting example

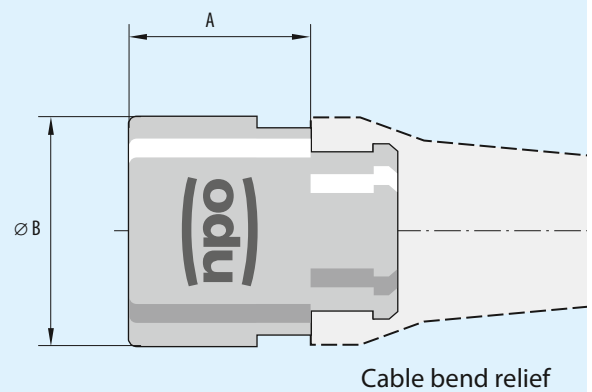

## Tools



## Crimping Tool



Part number crimping tool

080.000.051.000.000

Part number positioner

see table



### Crimping and Removal Tools for Crimp Contacts

Size	Number of contacts	Contact diameter	Cross section		Adjustment	Positioner	Position		Removal tool
			AWG	mm <sup>2</sup>			for pin	for socket	
0	4-5	0.7	28-32	0.09/0.04	0.57	080.000.051.105.000	1	2	087.7CC.070.001.000
	4-5	0.7	22-26	0.38/0.15	0.67	080.000.051.105.000	1	2	087.7CC.070.001.000
	2-3	0.9			0.67	080.000.051.105.000	3	4	087.7CC.090.001.000
	2-3	0.9	20-24	0.50/0.25	0.67	080.000.051.105.000	3	4	087.7CC.090.001.000
1	6-8	0.7	28-32	0.09/0.04	0.57	080.000.051.105.000	1	5	087.7CC.070.001.000
	6-8	0.7	22-26	0.38/0.15	0.67	080.000.051.105.000	1	5	087.7CC.070.001.000
	4-5	0.9			0.67	080.000.051.105.000	3	6	087.7CC.090.001.000
	4-5	0.9	20-24	0.50/0.25	0.67	080.000.051.105.000	3	6	087.7CC.090.001.000
	2-3	1.3	18-20	1.00/0.50	1.12	080.000.051.105.000	7	8	087.7CC.130.001.000
2	12-19	0.7	28-32	0.09/0.04	0.57	080.000.051.106.000	1	2	087.7CC.070.001.000
	12-19	0.7	22-26	0.38/0.15	0.67	080.000.051.106.000	1	2	087.7CC.070.001.000
	8-10	0.9			0.67	080.000.051.106.000	3	4	087.7CC.090.001.000
	8-10	0.9	20-24	0.50/0.25	0.67	080.000.051.106.000	3	4	087.7CC.090.001.000
	4-7	1.3			0.67	080.000.051.106.000	5	6	087.7CC.130.001.000
	4-7	1.3	18-20	1.0/0.50	1.12	080.000.051.106.000	5	6	087.7CC.130.001.000
	3	1.6	18-20	1.00/0.50	1.12	080.000.051.107.000	1	2	087.7CC.160.001.000
	3	1.6	18	1.50/1.00	1.12	080.000.051.107.000	1	2	087.7CC.160.001.000
	3		14-16		1.3				
	2	2.0	18		1.12	080.000.051.107.000	3	4	087.7CC.200.002.000
	2		14-16		1.3				
	3	20-30	0.7	28-32	0.09/0.04	0.57	080.000.051.106.000	1	7
20-30		0.7	22-26	0.38/0.15	0.67	080.000.051.106.000	1	7	087.7CC.070.001.000
14-18		0.9			0.67	080.000.051.106.000	3	8	087.7CC.090.001.000
14-18		0.9	20-24	0.50/0.25	0.67	080.000.051.106.000	3	8	087.7CC.090.001.000
8-10		1.3			0.67	080.000.051.106.000	5	9	087.7CC.130.001.000
8-10		1.3	18-20	1.00/0.50	1.12	080.000.051.106.000	5	9	087.7CC.130.001.000
7		1.6			1.12	080.000.051.107.000	1	5	087.7CC.160.001.000
7		1.6	18	1.50/1.00	1.12	080.000.051.107.000	1	5	087.7CC.160.001.000
7			14-16		1.3				

Tools

## Spanner Wrench

Part number	Dimensions in mm				
	SW	t	B	L	b
598.700.001.016.000	5	1.5	16	92	8
598.700.001.015.000	5.5	1.5	16	92	8
598.700.001.021.000	6	2	16	92	8
598.700.001.011.000	7	2	16	92	8
598.700.001.001.000	8	2	16	92	8
598.700.001.022.000	9	2	21.5	102	9
598.700.001.002.000	10	2	21.5	102	9
598.700.001.012.000	11	2	24.5	115	10
598.700.001.003.000	12	2.5	24.5	115	10
598.700.001.017.000	12.5	4	24.5	115	10
598.700.001.004.000	13	2.5	30.5	98	16.5
598.700.001.005.000	14	2.5	30.5	98	16.5
598.700.001.006.000	15	3	35.5	145	15
598.700.001.007.000	16	3	35.5	145	15
598.700.001.008.000	17	3	35.5	145	15
598.700.001.023.000	18	3	42	172	16
598.700.001.013.000	19	3	42	172	16
598.700.001.009.000	20	3	42	172	16
598.700.001.018.000	21	3	42	172	16
598.700.001.010.000	22	3	47	119	23.5
598.700.001.014.000	24	3	54	119	23.5
598.700.001.024.000	27	3	55	150	25
598.700.001.019.000	30	3	50	150	25
598.700.001.020.000	31	3	50	150	25

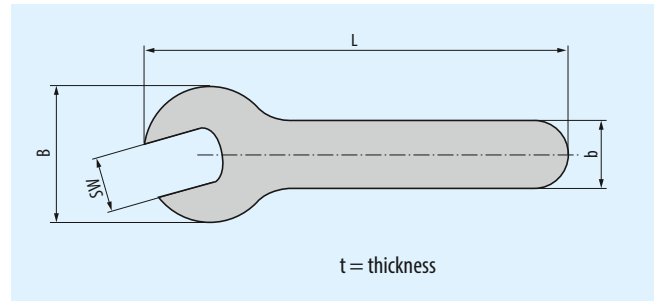

## Nutdriver for Slotted Mounting Nut

Tools

Part number nutdriver	Thread
Suitable for style 8 / series L and B:	
700.098.002.000.000	M 9 × 0.5
700.098.001.000.000	M 10 × 0.5
700.098.001.000.000	M 12 × 1
701.098.002.000.000	M 14 × 1
701.098.001.000.000	M 15 × 1
702.098.001.000.000	M 16 × 1
702.098.001.000.000	M 18 × 1
703.098.001.000.000	M 20 × 1
Suitable for style 3 / series K:	
701.098.002.000.000	M 14 × 1
721.098.001.000.000	M 16 × 1
703.098.001.000.000	M 20 × 1
724.098.001.000.000	M 30 × 1

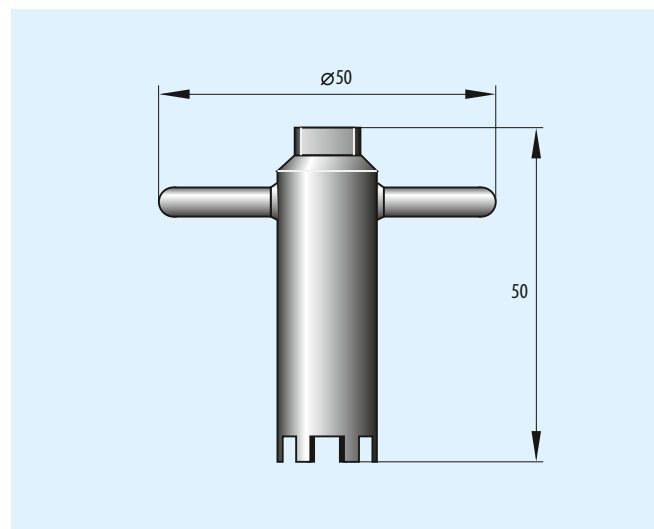

## Removal Tool for Crimp-Clip-Contacts

Part number	Contact diameter mm	
087.7CC.070.001.000	0.7	
087.7CC.090.001.000	0.9	
087.7CC.130.001.000	1.3	
087.7CC.160.001.000	1.6	

Crimp-clip-contact



Removal tool

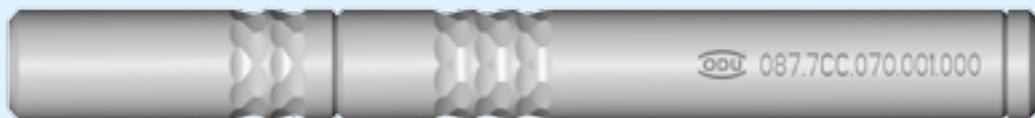

## Assembly Tool Series K

Part number: 080.000.055.000.000

- Useable from Size 0 until 4
- To clamp the inner housing for back nut assembly
- Incl. jaws for bench vise fixing for easy handling.

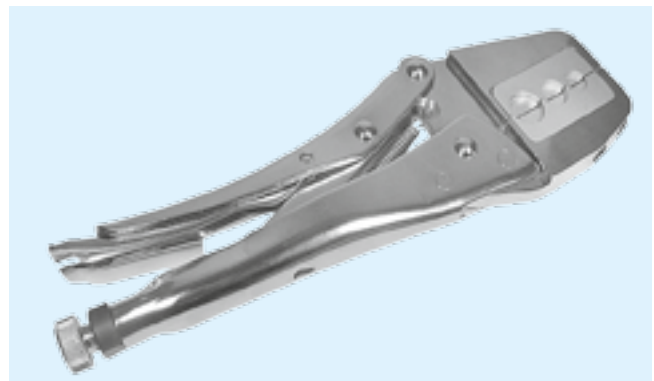



## Assembly Instructions

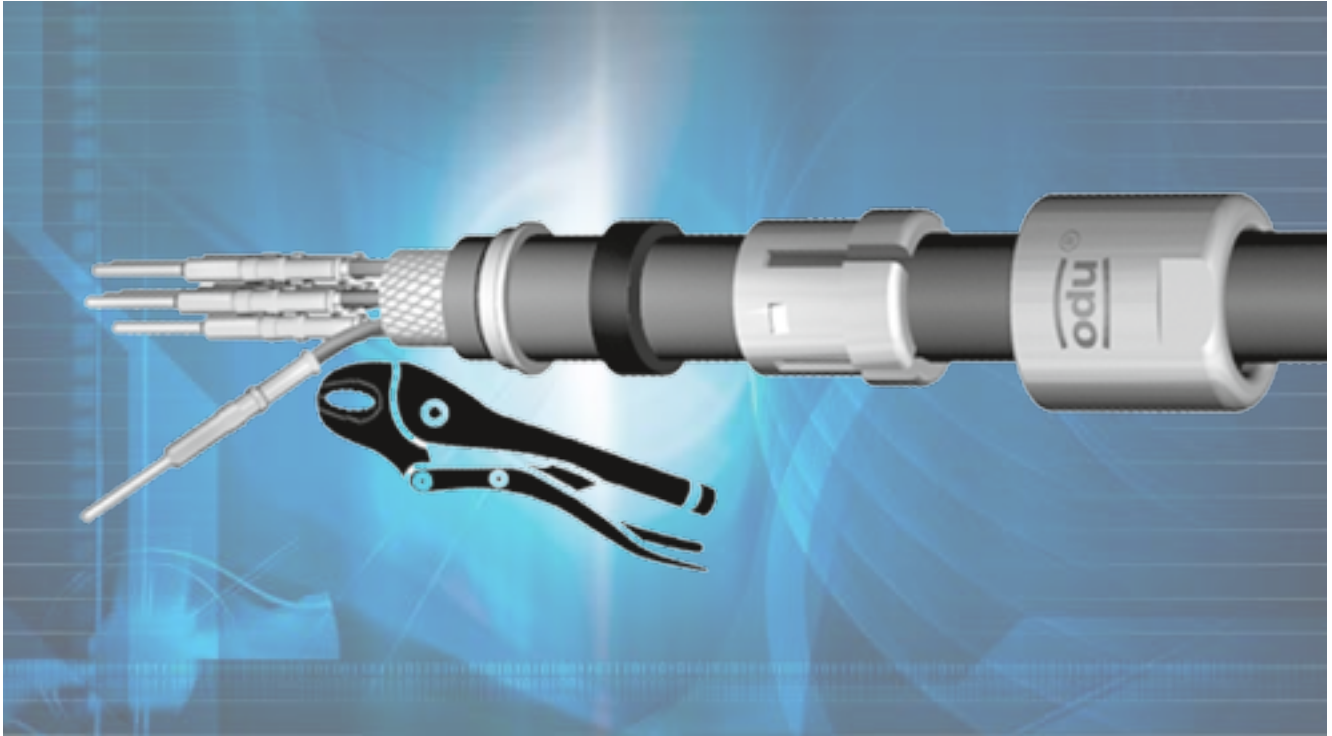

Assembly instructions are available for download on our website:  
[www.odu.de/downloadcenter.html](http://www.odu.de/downloadcenter.html)

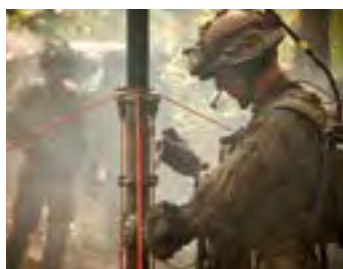

The following instruction sheets for assembly are available for download:

**Serie L**

- Unsealed right-angled plug connectors (IP 50).

**Serie K**

- Sealed connectors (IP 68), crimp termination
- Sealed connectors (IP 68), solder termination
- Sealed right-angled plug connectors (IP 68) .

**Serie B**

- Sealed connectors (IP 68), crimp termination
- Sealed connectors (IP 68), solder termination
- Sealed right-angled plug connectors (IP 68).

## Technical Information

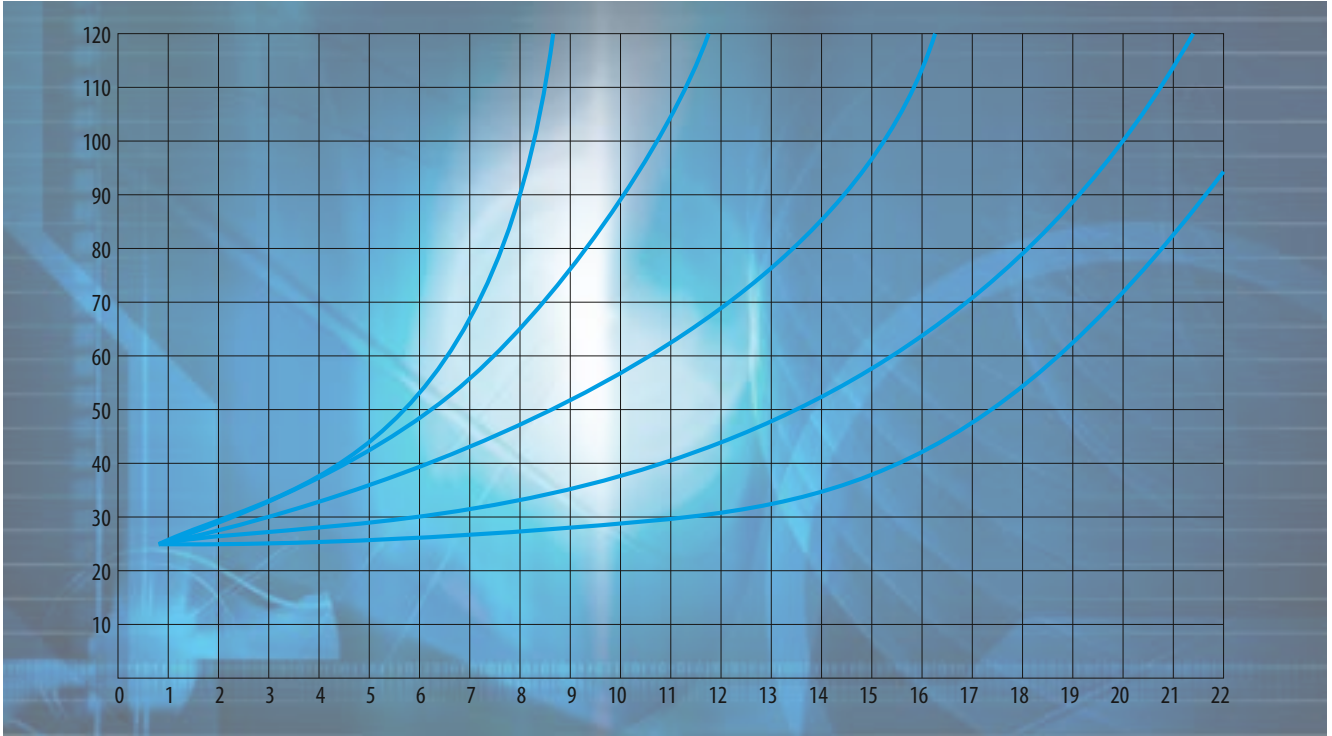

## International Protection (IP) Classes DIN EN 60 529 (respectively IEC 529 /VDE 0470 T1)

Code letters (International Protection)		First code number (Protection against solid foreign bodies)		Second code number (Protection against water)		
<b>IP</b>		<b>6</b>		<b>5</b>		
Code number	Extent of protection		Code number	Extent of protection		
<b>0</b>	No protection		No protection against contact, no protection against solid foreign bodies	<b>0</b>	No protection against water	No protection against water
<b>1</b>	Protection against large foreign bodies		Protection against large-surface contact with the back of the hand, protection against foreign bodies $\varnothing \geq 50$ mm	<b>1</b>	Protection against dripping water	Protection against vertically falling water drops
<b>2</b>	Protection against medium-sized foreign bodies		Protection against contact with the fingers, protection against foreign bodies. $\varnothing \geq 12$ mm	<b>2</b>	Protection against dripping water when tilted	Protection against falling water drops when tilted (any angle up to 15° from the vertical)
<b>3</b>	Protection against small foreign bodies		Protection against contact with tools, wires, or the like with $\varnothing \geq 2.5$ mm, protection against foreign bodies $\varnothing \geq 2.5$ mm	<b>3</b>	Protected against spraying water	Protection against water spraying at any angle up to 60° from the vertical
<b>4</b>	Protection against granular foreign bodies		The same as 3, except $\varnothing \geq 1$ mm	<b>4</b>	Protection against splashing water	Protection against splashing water from all directions
<b>5</b>	Protection against dust deposits		Protection against contact, protection against harmful dust deposit in the interior	<b>5</b>	Protection against water jet	Protection against water jet (nozzle) from any angle
<b>6</b>	Protection against dust ingress		Protection against foreign bodies $\varnothing \geq 1$ mm, protection against dust ingress	<b>6</b>	Protection against powerful water jet	Protection against powerful water jet from any angle
				<b>7</b>	Protection against immersion	Protection against water ingress during temporary immersion
				<b>8</b>	Protection against continuous immersion	Protection against pressurized water during continuous immersion
				<b>9k<sup>1</sup></b>	Protection against high pressure	Protection against water from high-pressure/ steam jet cleaners.

Technical Information

<sup>1</sup> IP x9k is not included in EN 60529 or IEC 60529, but is included in DIN 40 050-9.



## Watertightness

ODU offers IP 50 and IP 68 connectors in series B and L in the same outside diameter. Because ODU connectors must be compatible with other manufacturers, the

company also offers the series K. These connector is larger in diameter than the standard version (series L).

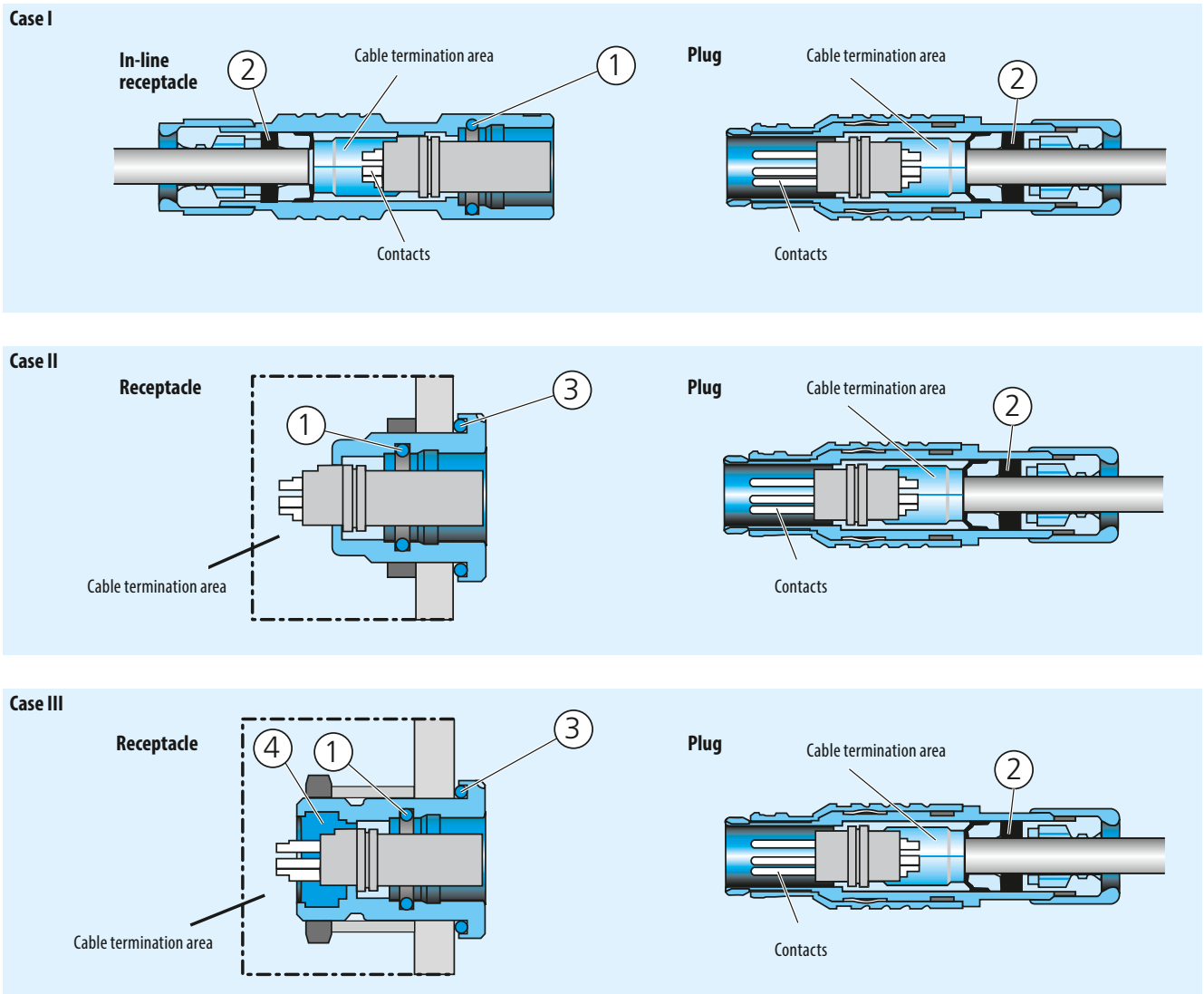

### Protection against water through following seals<sup>1)</sup>:

Case	Termination area	Mated		Unmated		No.	Sealing Part
		Sealed	Position	Sealed	Position		
I	Cable – termination area	Yes	1 2	No		1	O-ring
II	Device – termination area	Yes	1 2 3	No		2	Sealing ring <sup>2)</sup>
III	Device – termination area	Yes	1 2 3	Yes	3 4	3	O-ring
						4	Potting

<sup>1</sup> Contacts: in mated condition the contacts are protected (in cases I, II, III). In unmated condition the contacts can be protected using a protective cover (see page 89). The cover must be removed before mating the plug with the receptacle.

<sup>2</sup> The sealing ring acts as the cable sealing. It requires exact knowledge of the cable dimension. Important factors: Diameter tolerance, roundness, cable design and cable jacket hardness.

All IP 68 submersible ODU MINI-SNAP connectors are rated to 2 m water depth (0.2 bar) for 24 hours in accordance with DIN EN 60 529. A watertight plug requires a cable grommet in the collet. The grommet has to fit tightly over the cable. The cable jacket must be smooth, cylindrical and free of grooves. The plug should be potted for watertightness in unmated condition.

## Housing Materials and Surface Finish

ODU MINI-SNAP housings are made from brass and are nickel-plated with a matt-chromate surface finish (sand-blasted). Nickel-plated or black chromate-finished housings are available on special request. Inside metal components are made from nickel-plated brass.

Component parts	Material Designation	Surface Thickness of the film
Housing Back nut Slotted nut	Cu-alloy	Cr
Collet EMI ring Half-shells Locking washer Nut Retainer Ring	Cu-alloy	Ni
Pin (solder or PCB) Socket (solder or PCB) Pin (crimp) Socket (crimp)	Cu-alloy	Au

## Insulation Body Material ( RoHS 2011/65/EC recognized)

	Norm	Unit	PBT	PTFE <sup>1)</sup>	PEEK
Dialectric strength	DIN 53481	KV/mm	27	> 50	19
Operation temperature	ASTM D-149	°C	-40/+140	-100/+260	-50/+250
Flammability rating	UL-94	-	V-0	V-0	V-0
Creeping distance acc. to CTI	IEC 60 112		275	600	175

<sup>1</sup> PTFE (Teflon) is only used for coax and triax connectors.

## Termination Styles

Contact blocks (insulation bodies with contacts) are interchangeable between receptacle and plug. As a rule the socket contact blocks are mounted in the part under power.

ODU offers the following contact termination styles:

- Solder
- Crimp
- PCB.

### Termination styles for turned contacts

#### Solder termination

The contacts come mounted by the factory. The insulation body and the pre-assembled contacts are called a contact block.

#### Crimp termination

A single contact is crimped to a single conductor. Subsequently, the crimped contact is pushed into the insulation body. Crimp contacts and insulation bodies are shipped separately.

Crimping creates a reliable, corrosion-free and durable connection between the contact and the conductor. Crimping causes the crimp barrel of the contact and the conductor material to cold flow. It creates a gas-tight connection between contact and conductor.

The ODU MINI-SNAP generally requires the industry-standard 8-point crimping tool .

#### Printed circuit board (PCB) termination

PCB pins are used only for receptacles which are mounted directly to the PCB. The contacts are permanently installed in the insulation body.

#### Solder termination

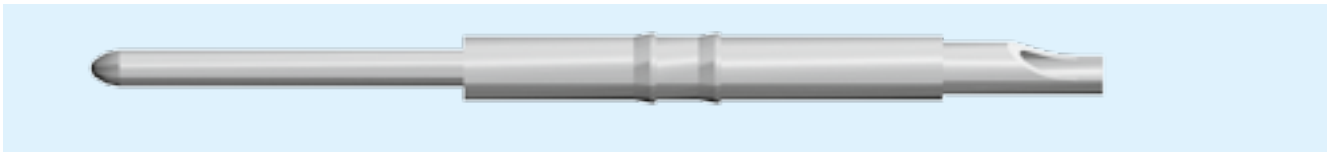

#### Crimp termination (Crimp-clip-contact for PEEK Insulator)

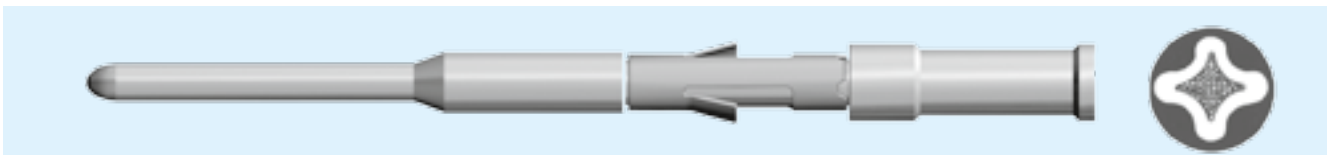

#### Printed circuit board (PCB) termination

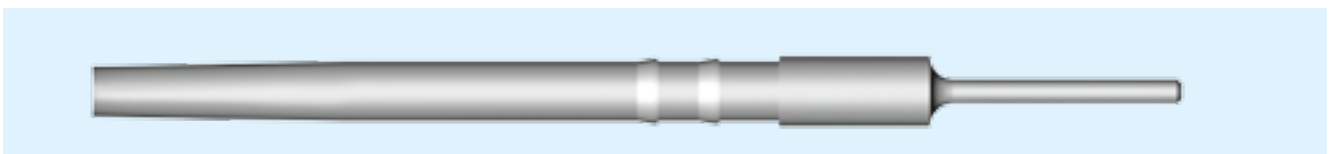

## Conversions AWG – Cross Section (AWG = American Wire Gauge)

The AWG system describes the cross section of a wire using a gauge number for every 26% increase in conductor cross section. With larger wire diameters, the AWG gauge numbers decrease; as the wire sizes increase, the AWG gauge numbers decrease. This is only valid for solid conductors.

Most wires are made with **stranded conductors**. Compared to solid conductors stranded wires offer higher durability, higher flexibility and better performance under bending and vibration.

Stranded wires are made from wires with smaller gauge sizes (higher AWG gauge number). The AWG gauge number of the stranded wire is equal to that of a solid conductor of the same size wire. The cross section of the stranded conductor is the sum of cross sections of the single conductors.

For example, a AWG-20 stranded wire of 7 AWG-28 conductors has a cross section of 0.563 mm<sup>2</sup>; an AWG-20 stranded wire with 19 AWG-32 conductors has a cross section of 0.616 mm<sup>2</sup>.

Conversion table AWG/mm<sup>2</sup>

Circular wire					
AWG	Diameter		Cross section mm <sup>2</sup>	Weight kg/km	Max. resistance Ω/km
	Inch	mm			
10 (1)	0.1020	2.5900	5.2700	47.000	3.45
10 (37/26)	1.1090	2.7500	4.5300	43.600	4.13
12 (1)	0.0808	2.0500	3.3100	29.500	5.45
12 (19/25)	0.0895	2.2500	3.0800	28.600	6.14
12 (37/28)	0.0858	2.1800	2.9700	26.300	6.36
14 (1)	0.0641	1.6300	2.0800	18.500	8.79
14 (19/27)	0.0670	1.7000	1.9400	18.000	9.94
14 (37/30)	0.0673	1.7100	1.8700	17.400	10.50
16 (1)	0.0508	1.2900	1.3100	11.600	13.94
16 (19/29)	0.0551	1.4000	1.2300	11.000	15.70
18 (1)	0.0403	1.0200	0.8200	7.320	22.18
18 (19/30)	0.0480	1.2200	0.9600	8.840	20.40
20 (1)	0.0320	0.8130	0.5200	4.610	35.10
20 (7/28)	0.0366	0.9300	0.5600	5.150	34.10
20 (19/32)	0.0384	0.9800	0.6200	5.450	32.00
22 (1)	0.0252	0.6400	0.3240	2.890	57.70
22 (7/30)	0.0288	0.7310	0.3540	3.240	54.80
22 (19/34)	0.0307	0.7800	0.3820	3.410	51.80
24 (1)	0.0197	0.5000	0.1960	1.830	91.20
24 (7/32)	0.0230	0.5850	0.2270	2.080	86.00
24 (19/36)	0.0252	0.6400	0.2400	2.160	83.30
26 (1)	0.1570	0.4000	0.1220	1.140	147.00
26 (7/34)	0.0189	0.4800	0.1400	1.290	140.00
26 (19/38)	0.0192	0.4870	0.1500	1.400	131.00
28 (1)	0.0126	0.3200	0.0800	0.716	231.00
28 (7/36)	0.0150	0.3810	0.0890	0.813	224.00
28 (19/40)	0.0151	0.3850	0.0950	0.931	207.00
30 (1)	0.0098	0.2500	0.0506	0.451	374.00
30 (7/38)	0.0115	0.2930	0.0550	0.519	354.00
30 (19/42)	0.0123	0.3120	0.0720	0.622	310.00
32 (1)	0.0080	0.2030	0.0320	0.289	561.00
32 (7/40)	0.0094	0.2400	0.0350	0.340	597.10
32 (19/44)	0.0100	0.2540	0.0440	0.356	492.00
34 (1)	0.0063	0.1600	0.0201	0.179	951.00
34 (7/42)	0.0083	0.2110	0.0266	0.113	1,491.00
36 (1)	0.0050	0.1270	0.0127	0.072	1,519.00
36 (7/44)	0.0064	0.1630	0.0161	0.130	1,322.00
38 (1)	0.0040	0.1000	0.0078	0.072	2,402.00
40 (1)	0.0031	0.0800	0.0050	0.043	3,878.60
42 (1)	0.0028	0.0700	0.0038	0.028	5,964.00
44 (1)	0.0021	0.0540	0.0023	0.018	8,660.00

Source: Gore & Associates, Pleinfeld

## Current Load – Contacts

### Nominal single contact current load for pin / slotted socket (nominal diameter 0.5 mm – 1.6 mm)

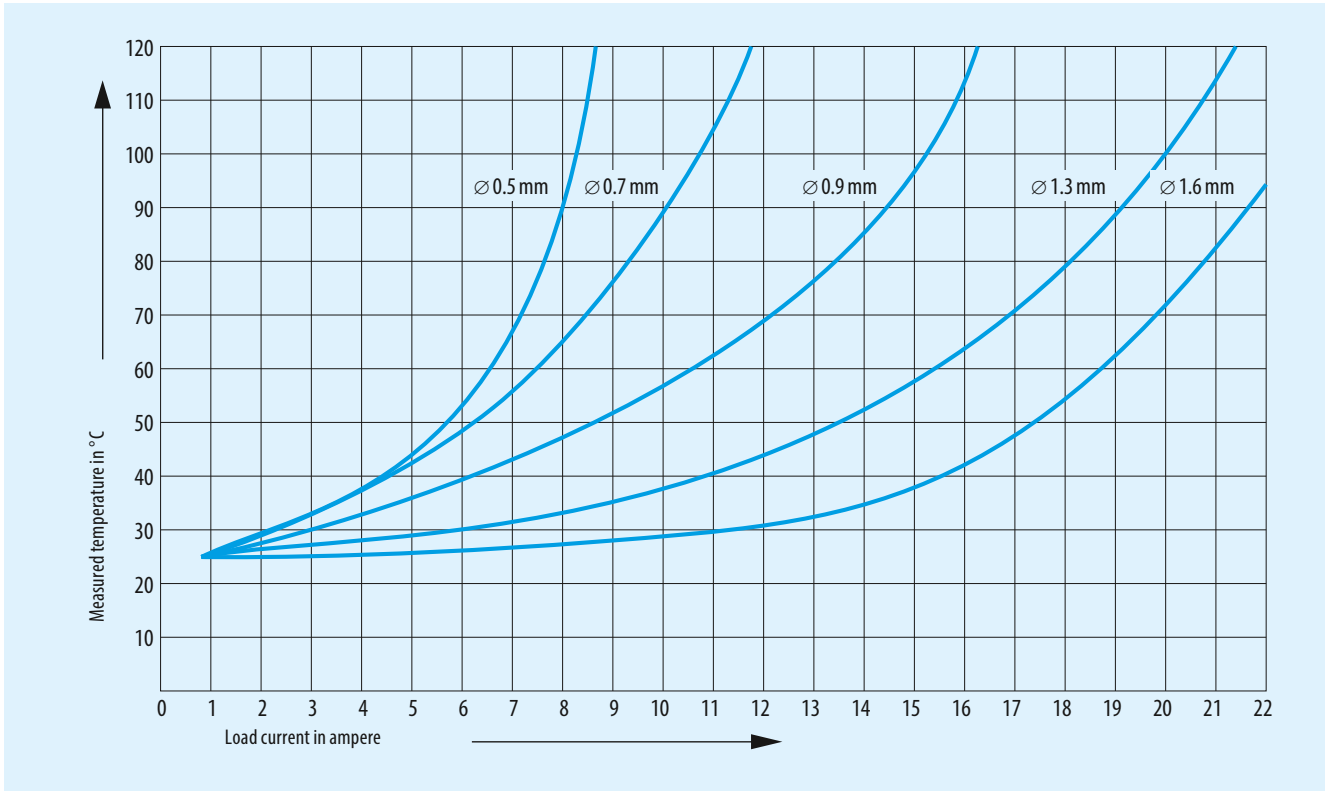

Maximum operating temperature for standard contacts:  
+120°C

Test contact was terminated to largest possible conductor.

Connectors or cables with more than one contact or conductor generate a higher heat than a single contact. Therefore, a **derating factor** must be applied.

For connectors the derating factor is applied according to DIN 57 298 Teil 4 / VDE 0298 Teil 2.

The derating factor is used starting with 5 loaded wires (DIN 41 640 T3).

#### Derating factor

Number of loaded wires	Derating factor
5	0.75
7	0.65
10	0.55
14	0.50
19	0.45
24	0.40

## Operating Voltage acc. to SAE AS 13441-Method 3001.1

The values acc. to SAE AS 13441-method 3001.1 comply with MIL-Std. 1344 – method 3001.  
The chart values results are acc. to IEC 60512-2; Test 4. The inserts have been tested in mated condition and the test voltage was applied to the pin insert.

75 % of the measured break-down voltage is the basic for the further calculation.  $\frac{1}{3}$  of this value is the corresponding operating voltage.

All tests were performed at standard environment conditions (room temperature) and can be applied up to an altitude of 2,000 m.  
For any deviations one has to consider the reduction factor acc. to the relevant standards.

**Test voltage:**  $\text{Break-down voltage} \times 0.75$   
**Operating voltage:**  $\text{Break-down voltage} \times 0.75 \times 0.33$

### Caution

Electrical appliances: for various applications the safety requirements regarding the operating voltage is even more severe!

The relevant datas in such cases for the operating voltage are the creepage and clearance distances. For any advise how to choose the proper connector please consult us and indicate the safty standard which your product has to meet.

## Electromagnetic Compatibility (EMC)

When discussing electromagnetic compatibility (EMC) one should not only consider the device or the circuit, but also include the network and the entire data communication link. This involves all connecting elements such as conductors and connectors. Electromagnetic interference from the outside into the connector can lead to system malfunctioning. The best way to prevent this is by providing a high-quality shield between the cable and the connector. In order to provide reliable EMC data to our customers we engaged the services of a certified test laboratory to investigate the EMC characteristics of the ODU MINI-SNAP. They tested for us size 00, 0, 1, 2 and 3 MINI-SNAP connectors.

Measurements were conducted using the inductive wire or parallel wire method in accordance with test procedure VG 55214-6-2. In this set-up, the mated connector is connected on one end to a network analyzer and terminated on the other end with a suitable impedance. The inductive wire is then mounted in close proximity along the mated connector pair. The induction wire is a ribbon cable which permits to vary the level of induction by using more or less of the ribbon conductors.

Next, a signal with a frequency range of 10 kHz to 3 GHz is connected to the ribbon cable. The network analyzer is used to measure the amount of signal induced into the

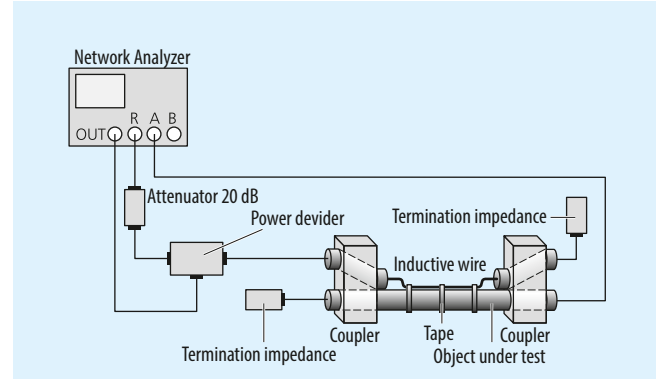

connector circuit. The result is shown as the shielding attenuation AT in dB. It is essential that all leads to the connector are shielded so that no signal can be induced into the circuit at any other place except the connector. The various attenuation values are plotted on a logarithmic scale as attenuation in dB vs. frequency.

An attenuation of better than -55 dB is generally required for reliable connector and system operation. It can be shown that our connectors will meet this requirement in all applications.

The following diagram is valid for all series and standard sizes.

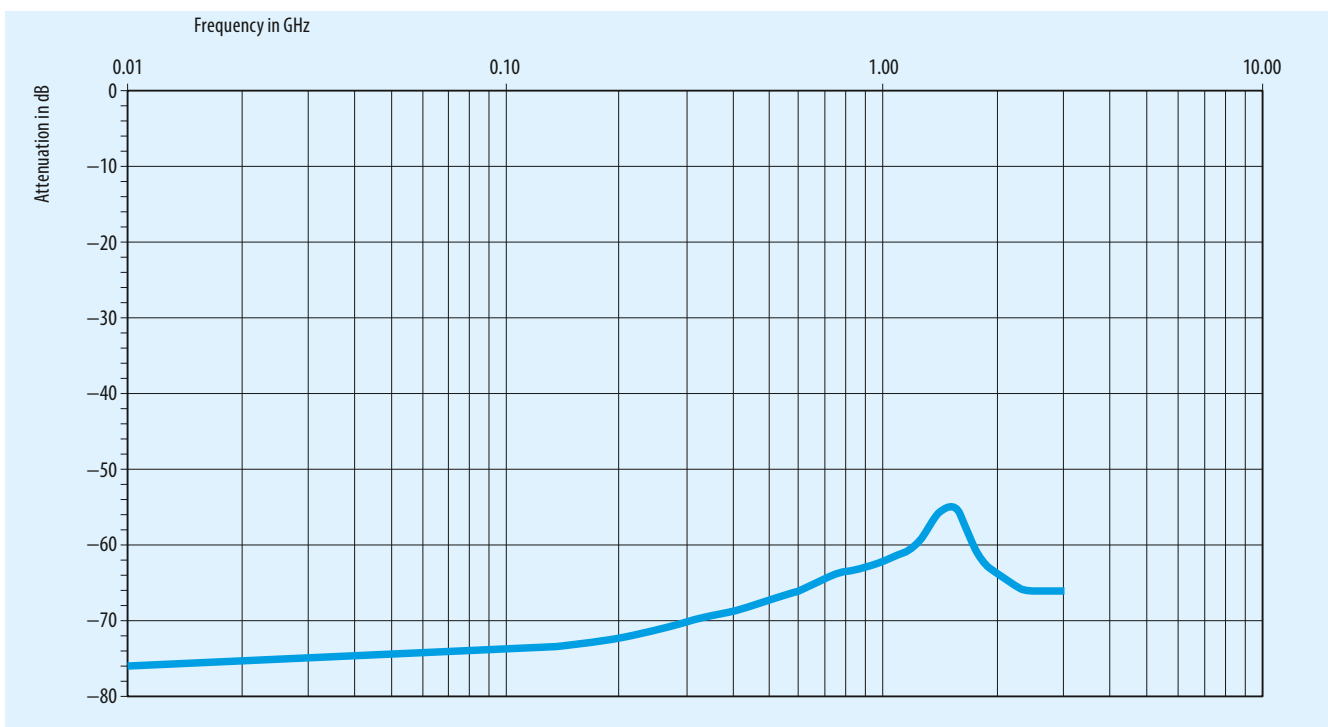

## Autoclaving of ODU MINI-SNAP Connectors

If required ODU can deliver MINI-SNAP connectors for the following sterilization process:  
 Steam-sterilization with pre-vacuum or gravitation-process.

Connectors were tested with autoklave equipment with reference to DIN EN 13060 at 134° C and 500 cycles.  
 For other sterilization-processes please contact our technical support team.

### Sterilization curve

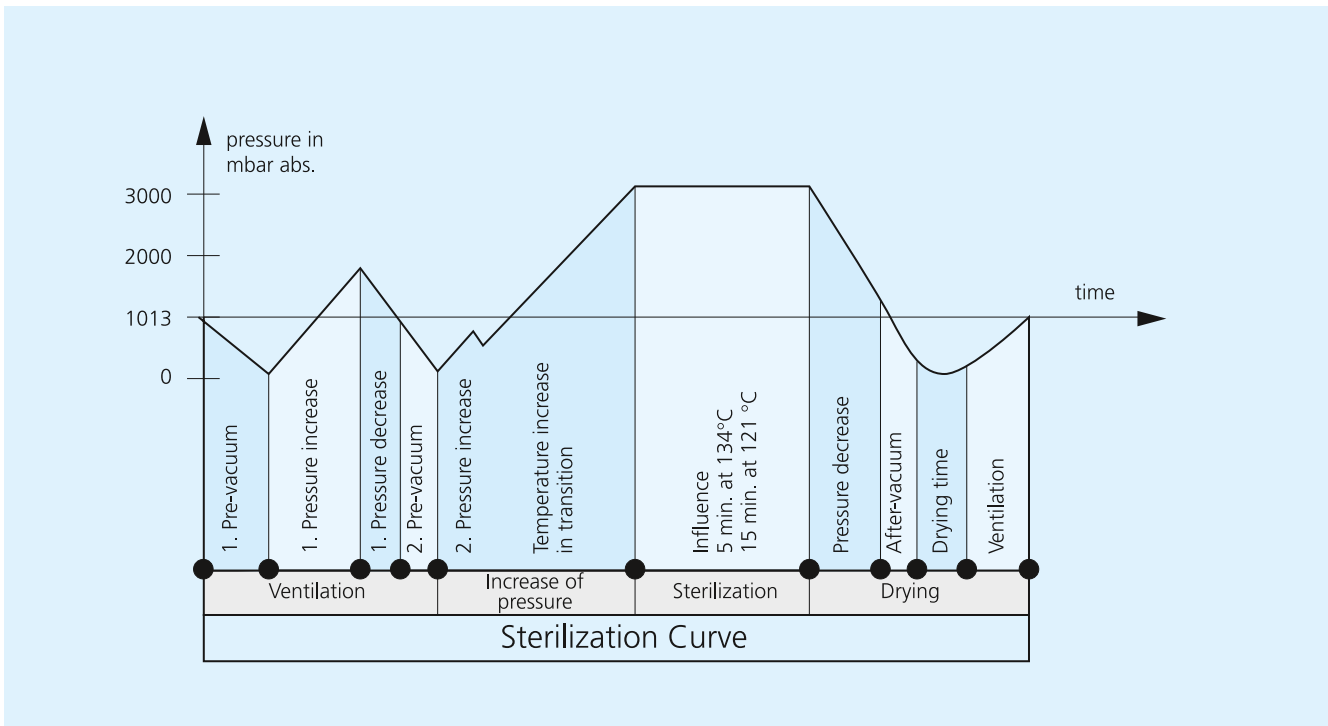



## Test Standard

In the scope of quality approval the sizes 0 and 3 have been submitted to environmental and mechanical tests acc. to MIL. All tests have been passed.

### Test carried out

Definition	Standard
High temperature	MIL-STD 810 F / PV 501
Low temperature	MIL-STD 810 F / PV 502
Temperature shock	MIL-STD 810 F / PV 503
Humidity	MIL-STD 810 F / PV 507
Salt fog	MIL-STD 810 F / PV 509 and MIL-STD 1344 A / Methode 1001.1
Shock	MIL-STD 810 F / PV 516
Vibration	MIL-STD 1344 A / Methode 2005.1 / IV
Water thightness IP 68	IEC 60529

## Technical Information / Definitions / Terms

**Air gap**

Shortest distance between two conductive elements through the air.

**Autoclavability**

See page [112](#).

**AWG**

See page [108](#).

**Creepage distance**

The distance measured across the surface of a dielectric between two contacts or a contact and a metal part. The longer the distance, the lesser the risk of damage or tracking. Minimum creepage distances are specified according to the operating voltage and the applicable isolation group.

**Crimping area**

The part of a crimp barrel at which the crimp connection is achieved by pressure deformation or by reshaping the barrel around the conductor.

**Crimp barrel**

A hollow part of a contact which accepts one or more conductors and which may be crimped through the application of a crimping tool.

**Crimp connection**

The permanent attachment of a contact to a conductor by pressure deformation or by reshaping the crimp barrel around the conductor so that a good electrical and mechanical connection is established. (See page [107](#)).

**Connector**

A component which terminates conductors for the purpose of providing connection and disconnection to a suitable mating component. Depending on the fastening to a cabinet, panel, rack etc. or a cable, they are classified.

**Delivery**

Delivery of the connectors usually as components (that means not assembled).

Exception: Solder contacts are factory-installed in the insulation body.

**Fixed connector**

A connector for attachment to a rigid surface (panel).

**Free connector**

A connector for attachment to the free end of a wire or cable. Also called free hanging connector or in-line receptacle.

**Insertion or withdrawal force**

The force required to fully mate or unmate a set of connectors without the effect of coupling, locking or similar devices. The insertion force is usually greater than the withdrawal force. Also called mating and unmating force.

**Insulation body**

Non-conductive part of a connector, to electrically and mechanically separate live parts and to protect against accidental touch.

**Insulation group**

Classification of connectors according to the operating and working conditions (insulation groups according DIN VDE 0110).

**Keying**

System of projections and grooves on mating connectors which prevent otherwise identical connectors from being mated. This is useful when several connectors of the same style are used in the same application (see page [9](#), [29](#), [47](#)).

**Lower limit temperature**

The lowest permissible temperature which a connector or a plug-in device is allowed to be operated.

**Materials**

The contacts are made of Cu-alloy and gold-plated. The standard housings are made of Cu-alloy with a matt-chromate surface finish. All other materials and surfaces on special request (see page [106](#)).

**Mating cycles**

Mechanical operation of connectors and plug-in devices by insertion and withdrawal. One mating cycle comprises one insertion and one withdrawal operation.

**Nominal single contact current load**

Current load, which can load every single contact (see page [109](#)).

**Nominal voltage**

Nominal voltage characterizes a component.

**Operating temperature of the ODU MINI-SNAP**

Range between upper and lower temperature limits. –40° C to +120° C (see page [7](#)).

**Print connection**

(see page [107](#)).

**Printed circuit board**

Boards, typically made of epoxy-filled glass fiber fabric, with conductive pattern on one or both sides, or in case of multilayer boards, also imbedded inside the board. They feature metallized holes for soldering wire-mounted components or for the insertion of resilient or rigid press-in pins or instead, pads for attaching components using surface mount technology (SMT).

**Reference current**

The current at which a connector can be operated permanently simultaneously through all contacts without reaching maximum temperature.

**Reference voltage**

Normal voltage (VDE 0110) for a connector.

**Solder termination**

(See page [107](#) termination styles)

**Termination cross-section**

The indicated cross-sections correspond to a flexible conductor design in accordance with EN 60228:2005 class 5 or to a flexible conductor design (7/19 strands) in accordance with AWG (ASTM B258-02).

**Termination techniques**

Methods for connecting a wire to an electro-mechanical component, e.g. solderless connection according to IEC 60352: respectively such as crimp, press-in etc. or solder connections.

**Test voltage**

The voltage the connectors are tested, and are being referred on definite characteristics.

**Upper limit temperature**

Highest permissible temperature at which a connector or a plug-in device is allowed to operate. This temperature includes the self-heating and the ambient temperature. At ODU MINI-SNAP +120° C (see page [109](#)).

**Watertightness**

See page [105](#)

**Wire**

Wires may be provided with an insulation cover, an electrical shielding. Cables or conductors may consist of one or more wires.

Connectors shown in this catalog are designed to operate at high voltages and high frequencies. Care must be taken to assure that no person can come in contact with live conductors during installation or operation of the connectors.

ODU reserves the right to change design and performance of any product to meet changing technical developments without prior notice. ODU reserves the right to discontinue any part in this catalog without prior notice and without obligation to continue production after the change.



## Company Information



## Quality Management

ODU has had a powerful quality management system in place for years. ODU has been successfully certified to ISO 9001 since 1994. In addition, the automotive sector of the company group is certified to ISO TS 16949. The certification process was carried out by the internationally active BVQI (Bureau Veritas Quality International) company.

ODU is also certified according to the medical standard ISO 13485:2003 + AC:2007.

Additional to this ODU is certificated to DIN EN ISO 14001 : 2009 as well as to different certifications: VDE, UL, UL wiring harness, SCA, VG, MIL.



## Your Partner in Many Application Areas



ODU stands for quality, flexibility and reliability. This is why customers working in many application areas rely on ODU products in markets such as the following:

- Medical
- Industrial
- Measuring and testing
- Military and security
- Energy
- Automotive.

Overview – All Push-Pull Connector Series from ODU

	Push-Pull series	Coding	Sizes	No. of mechanical coding	Diameter plug (mm)	Max. cable Ø (mm)	Max. no. of contacts	Solder	Crimp	Print	IP Protection Class A <sup>1)</sup>	IP Protection Class B <sup>2)</sup>
ODU MINI-SNAP L		Pin and groove	00	4	6.5	3.5	04				IP 50	up to IP 68
			0	6	9.5	5.6	10					
			1	7	12.0	7.7	16	●	●	●		
			2	8	15.0	9.9	26					
			3	7	18.0	11.9	30					
			4	1	25.0	16.0	40					
ODU MINI-SNAP K		Pin and groove	0	4	11.0	5.0	10				IP 68	up to IP 68
			1		13.0	7.0	16					
			2		16.0	9.0	26	●	●	●		
			3		19.0	10.5	30					
			4		25.0	14.0	40					
ODU MINI-SNAP B		Pin and groove	0	6	9.4	5.0	10				IP 68	up to IP 68
			1	8	12.0	7.0	16	●	●	●		
			2	8	15.0	9.0	26					
			3	10	18.0	10.5	30					
ODU MINI-SNAP S		Insulation body	0	1	9.4	5.0	04				up to IP 68	up to IP 68
			1		12.0	7.0	05	●	●			
			2		15.0	9.0	10					
ODU MINI-SNAP F		Half shell	0	2	9.4	5.0	09				up to IP 68	up to IP 68
			1	2	12.0	7.5	12					
			1.5	2	13.0	7.5	19	●	●	●		
			2	2	15.0	9.5	19					
			3	3	18.0	11.5	27					
ODU AMC		Pin and groove	0	4	14.0	5.5	10				up to IP 69K	IP 68
			1		15.9	6.5	16					
			1.5		16.5	8.0	19	●		●		
			2		19.6	10.0	26					
			3		23.9	11.5	37					
ODU MINI-SNAP PC		Half shell	1	3	12.5	6.0	14				up to IP 67	IP 50
			2		15.7	9.0	19	●	●	●		
			3		18.7	10.5	27					
ODU MEDI-SNAP		Pin and groove	1	6	13.7	6.5	14				up to IP 64	IP 50
			2	1	18.5	9.2	19	●	●	●		

<sup>1</sup> IP Protection Class in mated condition.

<sup>2</sup> IP Protection Class in unmated condition to the end device.



**The Complete ODU Product Range**

<p>Single contacts (round or flat)</p>			
<p>High current connectors</p>			
<p>Circular connectors with Push-Pull locking</p>			
<p>Modular rectangular connectors</p>			
<p>PCB connectors</p>			
<p>Robust connectors</p>			
<p>Disposable Systems</p>			
<p>Application specific solutions</p>			
<p>AMC – Advanced Military Connector</p>			
<p>Cable assembly</p>			

## Everything From One Source

Each connection needs its individual cable. Make no compromises when it comes to the quality of the complete connection system. ODU gives you the complete system solution from one source, with no intermediary suppliers.

Cable assembly is a very complex subject. It requires equal measures of expertise in the areas of connectors, cables and assembly. ODU meets all these requirements in full.

Our competent assembly team tests the complete system according to your specifications. Our assembly service promises you the same quality found in our connectors – without compromises.

### ODU offers you all from one source

- 100 % final inspections
- Production in clean room acc. to EN ISO14644-1 possible
- Automatic processes (cutting, stripping, attaching)
- Extrusion possible with a hot-melt and high pressure/temperature process
- Ultrasound welding
- EMC-compatible assembly
- Application specific labeling
- Widest range of potting possibilities for sealed systems
- Extruded cable crossovers.

### Advantages for the customer

- Modern manufacturing facilities in Mühldorf (Germany), Shanghai (China) and Sibiu (Romania)
- Reliability thanks to our company-wide quality strategy
- Products with durability and functional reliability
- Production according to UL (file: E333666) possible
- Inspections, such as crimp force monitoring, during production.



## Application Specific Connectors



Innovative, dynamic markets call for innovative connectors.

As an expert for special applications and requirements, we develop forward-looking, appropriate connectors attuned to your needs!

In spite of the global trend toward standardized connectors, there are always applications that call for an application specific solution. We accept this challenge and

develop innovative products for our customers based on our many years of extensive know-how, our creativity and, not least, our high level of vertical integration. Technology access and technology mastery, combined with intensive cooperation with the user, form the basis for achieving success together.

Design-to-cost is joined by design-for-application for the customer's benefit.



**Telefax Inquiry ODU MINI-SNAP L, K, B**

**Fax-No.: +49 8631 6156-49**

ODU Steckverbindingssysteme  
 GmbH & Co. KG  
 Pregelstr. 11  
 84453 Mühldorf a. Inn  
 GERMANY

Company: .....  
 Name: .....  
 Department: .....  
 Street: .....  
 City: .....  
 Phone: ..... Date .....

**ODU MINI-SNAP Summary of Technical Requirements**

1) Connector application \_\_\_\_\_  
 \_\_\_\_\_

2) Environment \_\_\_\_\_  
 \_\_\_\_\_

3) Connector type  Plug  Receptacle  In-line receptacle  
 90° Plug  90° Receptacle  In-line receptacle

4) Special version \_\_\_\_\_

5) Style \_\_\_\_\_

6) Size  00  0  1  2  3  4

7) Series  don't care  L  K  B

8) Coding \_\_\_\_\_

9) Number of positions \_\_\_\_\_

10) Termination  Solder  Crimp  PCB

11) Cross section of wire \_\_\_\_\_ mm<sup>2</sup> \_\_\_\_\_ AWG

12) Cable diameter \_\_\_\_\_ mm

13) Cable bend relief (colour) \_\_\_\_\_

14) Protection class acc. DIN EN 60 529  IP 50 (standard)  IP 68  other

15) Operating temperature \_\_\_\_\_ °C max \_\_\_\_\_ °C min

16) Electrical specs:  
 Operating voltage \_\_\_\_\_ V AC \_\_\_\_\_ V DC  
 Operating current \_\_\_\_\_ A (constant) \_\_\_\_\_ A (short-term) \_\_\_\_\_ sec.

17) Chemical resistance against \_\_\_\_\_

18) Other requirements \_\_\_\_\_

19) Autoclavable, 134° C  Yes  No

→ Required quantity \_\_\_\_\_

→ Production quantity \_\_\_\_\_



Please open



## **ODU GmbH & Co. KG**

Pregelstr. 11  
84453 Mühldorf a. Inn  
Germany

Phone: +49 8631 6156-0  
Fax: +49 8631 6156-49  
E-Mail: [zentral@odu.de](mailto:zentral@odu.de)

## **ODU France**

Phone: +33 1 3935-4690  
E-Mail: [odu@odu.fr](mailto:odu@odu.fr)

## **ODU Scandinavia**

Phone: +46 176 18261  
E-Mail: [sales@odu.se](mailto:sales@odu.se)

## **ODU UK**

Phone: +44 1509-266-433  
E-Mail: [sales@odu-uk.co.uk](mailto:sales@odu-uk.co.uk)

## **ODU USA**

Phone: +1 805 4840540  
E-Mail: [sales@odu-usa.com](mailto:sales@odu-usa.com)

## **ODU Shanghai Trading**

Phone: +86 21 58347828-106  
E-Mail: [oduchina@odu.com.cn](mailto:oduchina@odu.com.cn)

**Other qualified representatives  
shown on our website:  
[www.odu.de/sales](http://www.odu.de/sales)**